

OWATONNA PUBLIC UTILITIES

Electric Service Rules & Regulations



Issued: December 2020

**Our mission is to enrich the quality of life in our community
by delivering reasonably priced, reliable, safe, and
customer-focused utility services**

**OWATONNA PUBLIC UTILITIES
ELECTRIC SERVICE**

RULES AND REGULATIONS

Issued: December 2020

INTRODUCTION

Owatonna Public Utilities (hereafter referred to OPU) has assembled this booklet to assist its customers and their architects, engineers, or electrical contractors to plan for and obtain prompt and satisfactory electric service.

The information presented here is intended to supplement the requirements of the National Electrical Code (NEC), National Electric Safety Code (NESC) and all other applicable federal, or state, and municipal codes, regulations, laws and ordinances. It is always necessary to refer to and comply with such other codes, regulations, laws, and ordinances when planning, designing, and installing a new electrical service. Specific requirements of OPU do not intentionally conflict with any other requirements known to be in effect as of the publication date of this booklet. Any apparent conflicts of this nature should be brought to the attention of OPU for interpretation. OPU assumes no responsibility whatsoever for the manufacturer's, supplier's, electrician's, or engineering consultant's compliance with all applicable codes as well as all local and state codes. Any waiver at any time of OPU's rights or privileges under the electric service rules and regulations will not be deemed a waiver as to any breach of other matter subsequently occurring.

Power lines carry voltage that can cause shock, injury, or death. Contact OPU for guarding when working around electric wires. Please notify OPU immediately if you find electric equipment damaged, open, or unlocked.

OPU will be happy to confer with those customers desiring information concerning rates, services, etc., upon request by telephone or otherwise. Such requests should be directed to OPU's Customer Service Department located at the OPU Power Plant Office, 208 South Walnut Avenue, Owatonna, MN 55060. Phone (507) 451-2480, Fax (507) 451-4940.

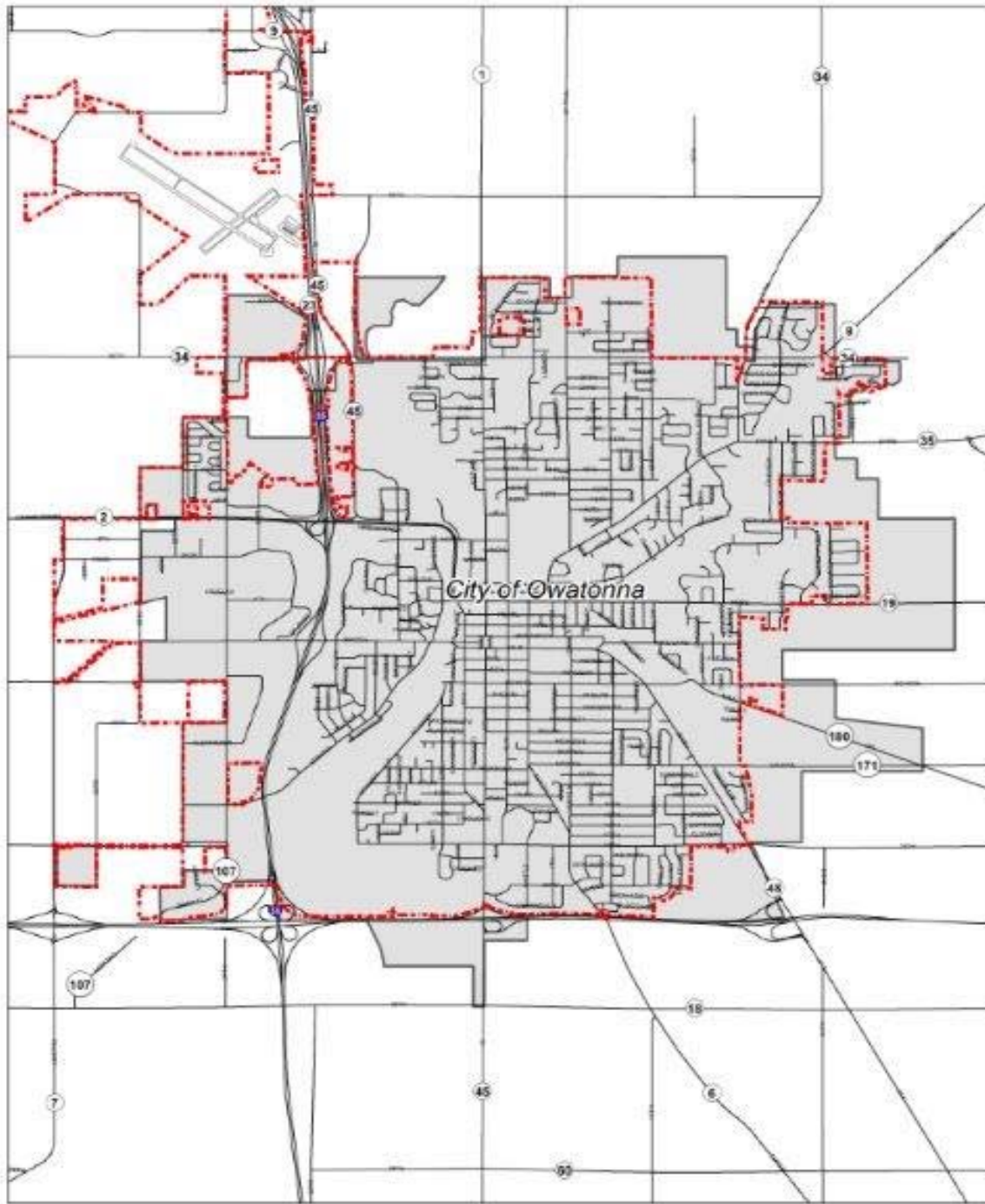

Owatonna Public Utilities Electric Territory



KEY

- Municipal Bndry
- OPU Electric Territory



205 S. Walnut Ave.
P.O. Box 800
Owatonna, MN 55060
Phone: (507) 451-2480
Fax: (507) 451-3695
owatonnautilities.com

TABLE OF CONTENTS

INTRODUCTION	2
SERVICE TERRITORY	3
TABLE OF CONTENTS	4
SECTION 100 – DEFINITIONS	8
SECTION 200 – GENERAL INFORMATION	12
201 – Service Jurisdiction	12
202 – Application for Residential Service	12
203 – Application for Commercial Service	12
204 – Ownership of Equipment	13
204.1 – OPU Owned Equipment	13
204.1(a) – Overhead Service	13
204.1(b) – Underground Service	13
204.2 – Customer Owned Equipment	13
204.2(a) – Overhead Service	13
204.2(b) – Underground Service	13
205 – Easements	13
206 – Inspection of Customer’s Facilities	14
206.1 – Requirements	14
206.2 – Inspections	14
206.3 – Connection Refusal	14
207 – Service Connection, Disconnection and Reconnection	14
207.1 – Site Readiness	14
207.2 – Notification	14
207.3 – Building Demolition	14
207.4 – Fire Disconnection & Reconnect	15
208 – Liability	15
209 – Service Interruptions	15
210 – Access	16
211 – Customer Responsibility	16
212 – Revisions of Requirements	16
213 – Damaged Utility Facilities	16
213.1 – Cutting of Service Wires	16
214 – Posting of Signs on Utility Poles	17
215 – Tree Planting	17
216 – Tree Trimming Policy	17
217 – Meter Tampering	17
SECTION 300 – RATES, CONNECTION CHARGES & CREDIT POLICY	18
301 – Rate Schedule Classification	18
302 – Payment	18
303 – Customer Charge	18
303.1 – Meter Fee	18
303.2 – Service Connection Fee	19
304 – Service Disconnection/Reconnection	19

304.1 – Disconnections with Notice	19
304.2 – Disconnections without Notice	19
304.3 - Reconections	19
305 – Service Deposit	19
305.1 – New Customer Criteria	19
305.2 – Current Customer Criteria	19
305.3 – Payment Method	19
305.4 – Refund and Interest	19
305.5 – Deposit Amounts	19
306 – Security Lighting	20
SECTION 400 – STANDARD SERVICES	21
401 – General Characteristics	21
402 – Availability of Service	21
403 – Secondary Service Voltage	21
403.1 – Single Phase Service	21
403.2 – Three Phase Service	21
404 – Primary Service Voltages	22
SECTION 500 – SPECIAL SERVICES	23
501 – Temporary Service Requirements	23
501.1 – General	23
501.2 – Address	23
501.3 – Overhead Service	23
501.4 – Underground Service	23
501.5 – Construction Safety	23
501.6 – Installation Length	23
501.7 – Fees	24
502 – Services for Unusual Load Characteristics	24
503 – Excess Facilities	24
504 – Redundant Facilities	24
505 – Relocation or Protection of OPU Facilities	25
506 – Rewiring or Upgrading Existing Facilities	25
SECTION 600 – METERS	26
600 – General	26
600.1 – Meter Bypass	26
601 – Responsibilities for Providing Metering Equipment	26
602 – Location of Meters	26
602.1 – Clearances	26
602.2 – Accessibility	27
602.3 – Industrial and Commercial	27
602.4 – Height Limits	27
602.5 – Residential	27
602.6 – Multi-Family Dwelling	27
602.7 – Mobile Homes	27
602.8 – Commercial Multi-Metering Panels	28
603 – Grouped Meters	28

604 – Meter Identification	28	
605 – Meter Mounting	29	
605.1 – Outdoor Meters and Meter Mounting Devices	29	
605.2 – New Customer Preferred Meter Location(s)	29	
605.3 – Upgraded or Rewired Service Location(s)	29	
605.4 – Indoor Meters Where Permitted	29	
606 – Meter Connections	29	
607 – Wiring Restrictions on Meters and Metering Sets	30	
608 – Meter Testing	30	
609 – Meter Seals	30	
610 – Instrument Transformer Installation	31	
610.1 – Where Required	31	
610.2 – Secondary Metering Instrument Transformer Cabinet	31	
610.3 – Conduit Requirements	31	
610.4 – Underground Service from Pad Mounted Transformers	32	
610.5 – Overhead Services	32	
610.6 – Indoor Mounted Instrument Transformers	32	
610.7 – Outdoor Primary Metering Equipment	32	
611 – Self-Contained Meter Installations	32	
611.1 – Single Phase Commercial	32	
611.2 – Three Phase Commercial	32	
611.3 – Minimum Rating	32	
612 – Master Metering Installations	32	
613 – Self-Contained Sockets	33	
613.1 – General Requirements	33	
613.2 – Customer Furnished	34	
613.3 – Approved Bypass	34	
614 – Instrument Transformer Sockets	34	
614.1 – OPU Furnished	34	
615 – Service at 480 Volts	34	
616 – Loc. of High-Leg in Meter Socket on 240/120 Volt, 3-Phase Service	34	
617 – Removing OPU Seals and Meters	34	
618 – Customer Generation	34	
619 – Proper Grounding/Bonding of Meter Sockets & Services	35	
619.1 – Neutral for 7 and 7 Terminal Sockets	35	
620 – Customer Disconnect Switch	35	
621 – Special Sockets	35	
622 – OPU Owned Equipment	35	
623 – Temporary Loosening of Customer Owned Meter Sockets by OPU Personnel	36	36
624 – Clearances from Gas Meters	36	
SECTION 700 – CUSTOMER UTILIZATION EQUIPMENT	37	
701 – Protection of Customer Equipment	37	
702 – Motor Starting Currents	38	
702.1 – General	38	
702.2 – Voltage Flicker	38	

703 – Power Factor	38
704 – Fault Currents.....	38
705 – Wiring Adequacy	39
706 – Customer-Owned Generating Equipment	39
707 – Customer’s Obligations	39
707.1 – Increased Load.....	39
707.2 – Balancing of Load.....	39
708 – Total Harmonic Distortion (THD)	39
708.1 – Nonlinear Load Requirements	39
708.2 – Nonlinear Load Disclosure.....	39
708.3 – Nonlinear Load Responsibilities	39
708.4 – Nonlinear Load Damages	40
709 – Carrier Current – Customer Responsibilities and Limitations	40
SECTION 800 – OVERHEAD SECONDARY SERVICES	41
801 – Maximum Transformer Size	41
802 – Service Drop Conductors	41
803 – Overhead Clearances	41
804 – Point of Attachment.....	42
805 – Service Entrance	42
SECTION 900 – UNDERGROUND SERVICES	43
901 – New Residential Developments.....	43
902 – Residential Undergrounding in Overhead Areas	43
903 – Underground Service to Dwellings	43
904 – Underground Service to Commercial and Industrial Customers.....	44
905 – Secondary Connection Cabinets	45
906 – Transformer Clearances.....	46
907 – Winter Installation.....	46
908 – Total Undergrounding.....	46
909 – Service Relocation	47
SECTION 1000 – UNDERGROUND LOCATIONS	48
1001 – One-Call	48
1002 – Excavation.....	48
1003 – Requests	48
1004 – Contact with Electric Cable	48
1005 – Damages.....	49
SECTION 1100 – TRANSFORMERS AND TRANSFORMER DATA	50
1101 – Transformers	50
1102 – Grounding	50
1103 – Special Rules	50
1104 – Fault Current	50
SECTION 1200 – EXHIBITS.....	52

SECTION 100

DEFINITIONS

Application for Service: The agreement or contract between OPU and the Customer under which electric service is supplied and taken.

Accessible: Allowing or admitting, close approach; not guarded by locked doors, elevation, or other effective means including any portion of a temporary or permanent structure.

Approved: Acceptable to the authority having jurisdiction.

Building: A structure with roof and walls. Two (2) or more structures shall not be considered a single building merely by the existence of skyways, tunnels, common heating or cooling facilities, common garages, entry halls or elevators, or other attachments.

Connected Load: The combined manufacturer's rated capacity of all motors and other electric energy consuming devices on the Customer's premises which may, at the will of the Customer, be operated with the electric energy to be supplied from the service of OPU.

Contractor: Licensed individual or company who performs work on behalf of the Customer or OPU.

Current Transformer: An instrument transformer designed for the measurement or control of current.

Customer: Any individual, partnership, corporation, or other legal entity now being served or to be served, using the electric service of OPU at any specified location.

Customer's Service Equipment: The necessary equipment and accessories, located near the point of entrance of supply conductors to a building, which constitute the main control and means of disconnecting the supply to that building. This equipment usually consists of a circuit breaker or a switch and fuses.

Disconnection Means: A device, or group of devices, or other means by which the conductors of a circuit can be disconnected from their source of supply.

Distribution Lines: OPU's lines located along streets, alleys, highways, or easements on private property, when used or intended for use for general distribution of electric service to Customers.

Dwelling:

Dwelling Unit: One or more rooms for the use of one or more persons as a housekeeping unit with space for eating, living and sleeping, and permanent provisions for cooking and sanitation.

Multi-Family Dwelling: A building containing two (2) or more dwelling units.

Single-Family Dwelling: A building consisting solely of one dwelling unit.

Easement: The right of use over the property of another, such as a right-of-way.

Prescriptive Easement: An easement upon another's real property acquired by continued use without permission of the owner for a period provided by state law to establish the easement.

Electric Service: The availability of electric power and energy, regardless of whether any electric power and energy is actually used. The supplying of electric service by OPU consists of the maintaining, at the point of delivery, approximately the agreed voltage, phase and frequency by means of facilities adequate for carrying the load which OPU is thereby obligated to supply by reason of the known requirements.

Excess Facilities: Those instances where OPU provides distribution and/or metering facilities at the Customer's request, in excess of the facilities OPU deems necessary to supply Electric Service to the Customer.

Fault Current: The current that will flow through the system to a point where a piece or a conductor has failed, such as bare conductors touching together or a bare conductor touching a ground point.

Frost (Frozen Ground): A condition where the water contained within the ground freezes, resulting in additional difficulty and expense in excavation work.

Instrument Transformer: A transformer that reproduces in its secondary circuit, the voltage or current proportional to its primary circuit.

Instrument Transformer Cabinet: A cabinet installed and owned by the Customer, complying with OPU's requirements, and designed for housing instrument transformers used for metering.

Master Metering: Metering configuration where a single meter (master meter) measures the consumption for a building, and then sub meters on the Customer side of the Master Meter measure the consumption of individual load, loads, or groups of loads.

Meter/Meter Set: An instrument or instruments, together with auxiliary equipment for measuring the electric power and energy supplied to a customer.

National Electrical Code (NEC): The current edition of the National Electrical Code as issued by the National Fire Protection Association (NFPA No. 70).

National Electric Safety Code (NESC): The current edition of the National Electric Safety Code as issued by the American National Standards Institute (ANSI C2).

Nominal Voltage: The value, expressed in volts, which is assigned to a circuit or system for the purpose of conveniently designating its voltage class (such as 120/240, 277/480Y, etc.). The actual voltage at which a circuit operates can vary from the nominal within a range established by ANSI C84.1. The Customer is responsible for making sure that their systems are capable of operating with range B of ANSI C84.1.

OPU: Owatonna Public Utilities.

Outside Sale: The sale or provision of electrical supply by a Customer to any other person outside the Customer's building or property.

Overhead Distribution Areas: The area or areas served by OPU's overhead distribution system as differentiated from the underground systems.

Point of Delivery: The point where the electric energy first leaves the line or apparatus owned by OPU and enters the line or apparatus owned by the customer. This is not necessarily the point of location of OPU's meter.

Point of Interconnection: The location designated by OPU that the Customer must extend conduits to in order for OPU to install our facilities on Customer property.

Primary Service: Any type of service with a nominal voltage greater than 600 volts.

Rate Schedules: The classification of the use of electricity into categories considering the amount of power supplied and the purpose of its use.

Redundant Facilities: Duplicate (partial or full) facilities installed at the request of the Customer for the purpose of increasing reliability of the system for a particular Customer.

Secondary Connection Cabinet: Cabinet required when the number and/or size of the conductors exceeds OPU's limit for terminating in a specific pad-mounted transformer. If a secondary connection cabinet is used, it will also be the location of the metering equipment.

Secondary Service: Any type of service with a nominal voltage less than or equal to 600 volts.

Secondary Terminal: The secondary side of a pad-mounted transformer, a secondary terminal box at the base of a riser pole, or a secondary junction box, whichever is designated by OPU.

Service: The conductors and equipment for delivering energy from OPU's system to the wiring system of the customer.

Service Drop: The overhead service conductors from the last pole or other aerial support to and including the splices, if any, connecting to the service-entrance conductors at the building or other structure.

Service Entrance Conductors, Overhead System: The service conductors between the terminals of the service equipment and a point usually outside the building, clear of building walls, where joined by tap or splice to the service drop.

Service Entrance Conductors, Underground System: The service conductors between the terminals of the service equipment and the point of delivery.

Service Equipment: The necessary equipment, usually consisting of a circuit breaker or switch and fuses, and their accessories, located near the point of entrance of supply conductors to a building or other structure, or an otherwise defined area, and intended to constitute the main control and means of cutoff of the supply.

Submetering: The provision of metered electrical supply through a Customer owned meter to a Customer's tenants, cooperative or condominium owners, other occupants, or to a portion of the Customer's own electrical consumption.

Underground Residential Distribution (URD) Areas: Those residential subdivisions or other specified areas within which all customers are served by underground distribution lines.

Underground Service Lateral: The secondary service conductors from OPU's distribution system.

Upgrade Service: An electric service is considered upgraded if the rating of the Customer disconnect is increased, or if either the conductors between the meter socket and the Customer disconnect or the conductors on the supply side of the meter are changed.

Utility: For the purpose of this document any public, city, or city-franchised organization that furnishes electric service.

Voltage to Ground: For grounded circuits, the voltage between the given conductor and that point or conductor of the circuit that is grounded; for underground circuits, the greatest voltage between the given conductor and any other conductor of the circuit.

Voltage Transformer: An instrument transformer intended for use in the measurement or control of a circuit and designed to have its primary winding connected in parallel with the circuit.

DRAFT

SECTION 200

GENERAL INFORMATION

201 SERVICE JURISDICTION

OPU has been established by the residents of Owatonna for the purpose of providing electricity to the residents of the City. OPU also provides electricity to residents outside of the City limits but within the service area boundaries established by the State of Minnesota. Service will be provided to all eligible applicants only when all applications, agreements, easements, deposits, payments, and other required information have been provided to OPU.

202 APPLICATION FOR RESIDENTIAL SERVICE

Application for new, additional, or temporary electric service must be made by the Customer, or a designated representative, at the OPU Office located at 208 South Walnut Avenue, in person, or fill out an application for service online at www.owatonnautilities.com. At the time of application, the Customer is required to provide the following information relating to the service request:

- (1) Official plan set that was submitted and approved by the City of Owatonna Building Inspections Department (this will be the field copy that is kept on the job site)
- (2) An 11x17 or 8.5x11 size site plan showing the footprint of the construction on the lot. This drawing must be to a usable scale. The drawing must show the lot lines, easements, buildings, window wells, concrete, retaining walls and any other permanent structures that will be constructed.
- (3) A completed copy of OPU's Responsible Party and Utility Loading Information form, obtained from OPU's website (www.owatonnautilities.com) or from the example form found in Section 1200, Exhibits.

203 APPLICATION FOR COMMERCIAL SERVICE

Application for new, additional, or temporary electric service must be made by the Customer, or a designated representative, at the OPU Office located at 208 South Walnut Avenue, in person, or fill out an application for service online at www.owatonnautilities.com. At the time of application, the Customer is required to provide the following information relating to the service request:

- (1) Official plan set that was submitted and approved by the City of Owatonna Building Inspections Department (this will be the field copy that is kept on the job site). This set must include construction drawings specifying the type of service required by the Customer, the proposed service entrance layout, and expected magnitudes of connected and peak load anticipated.

- (2) The name, address, and telephone number of the Customer's designated representative who will be responsible for working with OPU's Engineering Department in providing the electric service (e.g. Customer employee, engineer, contractor, etc.).
- (3) The approximate date that electric service is required

OPU should be advised of planning installations as early as possible so that details for furnishing service may be arranged and construction completed by the desired date.

204 OWNERSHIP OF EQUIPMENT

204.1 OPU-Owned Equipment - The meter and associated metering equipment furnished or installed by OPU are the property of OPU.

204.1 (a) Overhead Service—In addition to the metering equipment, the overhead service drop installed by OPU is the property of OPU.

204.1 (b) Underground Service—In addition to the metering equipment, all equipment up to, and including the designated point of delivery, is the property of OPU.

204.2 Customer-Owned Equipment - The meter socket, instrument transformer compartment (if required, see Section 610), the service entrance conductors and conduit from the meter socket to the service entrance disconnect, the service entrance switch or circuit breaker, the service entrance ground equipment, and the concrete transformer pad and grounding grid are the property of the Customer.

204.2 (a) Overhead Service—In addition to the equipment on the Customer side of the meter socket, the service drop wire holder or bracket, the weather head and either the service mast and conduit with entrance wires or the service entrance cable with watertight connection to the meter socket are the property of the Customer.

204.2 (b) Underground Service—In addition to the equipment on the Customer side of the meter, all conduit and cable required to extend the secondary service lateral from OPU's point of delivery to the meter socket are the property of OPU.

The Customer and OPU are responsible for the installation, maintenance, repair, and replacement of the electric service equipment which each owns.

205 EASEMENTS

Whenever any OPU-owned underground and/or overhead material and equipment is located on or above the Customer's property, the Customer shall grant an easement to OPU to the extent which OPU deems necessary. All utility easements required by OPU are to be granted by the Customer at no cost to OPU (this does not include secondary service

drops or service laterals). The Customer must provide a legal description by a Registered Land Surveyor. The easement will be signed and recorded by OPU.

206 INSPECTION OF CUSTOMER'S FACILITIES

206.1 Requirements – As a minimum, wiring and electrical equipment of the Customer shall be installed in accordance with the latest edition of the National Electrical Code (NEC).

206.2 Inspections – Customers living within the service area of OPU and requesting service from OPU must have their wiring inspected and approved by an authorized State of Minnesota electrical inspector. OPU will make connection before authorization from the state electrical inspector only if the master electrician who installed or supervised the installation agrees in writing to be responsible for said wiring until such time that it can be inspected and approved by an authorized State of Minnesota electrical inspector (“Request for Electrical Inspection” – white form).

206.3 Connection Refusal - Refusal to permit an authorized State of Minnesota electrical inspector to properly examine the Customer's wiring will be cause for OPU to refuse to connect the premises to electrical service or to discontinue the existing service until such time as the wiring may be inspected. Service connection may also be refused if the wiring is not completed in conformance with the National Electric Code (NEC) as determined by the authorized State of Minnesota electrical inspector.

207 SERVICE CONNECTION, DISCONNECTION AND RECONNECTION

207.1 Site Readiness – After the Customer's installation has been inspected and approved by the proper authority, a meter will be installed by OPU and the electric service made available provided that all applications, fees, agreements, and deposits have been submitted by the Customer and approved by OPU. Inspection notices must be received by OPU no later than 3:00 p.m. of the day preceding the date that connection is desired (weekends and holidays excluded). Under special circumstances, verbal inspections will be accepted as long as written inspection documentation is submitted immediately thereafter.

207.2 Notification – Customer requests for disconnection or reconnection of existing services must be received by OPU at least 48 hours in advance of the desired time of disconnection or reconnection (weekends and holidays excluded). For the mutual protection of the Customer and OPU, only authorized employees of OPU are permitted to set and remove meters, or to make and energize or break and de-energize the connection between OPU's service drop or secondary terminals and the Customer's service entrance conductors or underground service laterals.

207.3 Building Demolition – If a building is scheduled to be torn down, the wrecker shall notify OPU for a service disconnect a minimum of one (1) week prior to wrecking the building. The wrecker shall furnish to OPU a copy of the City of Owatonna Application for Building Demolition Permit approval form, complete with all applicable signatures, at the OPU Power Plant office. OPU will then issue a work order to disconnect service at no cost to the wrecker.

If at some future time the owner at the location requires service, the owner shall be required to make a new “APPLICATION FOR SERVICE” request, pay any and all liens or amounts encumbered by OPU and/or any outstanding OPU charges before an account will be reactivated.

207.4 Fire Disconnect & Reconnect – Upon request by the Owatonna Fire Department, OPU will dispatch the appropriate crew(s) to disconnect electric service at the meter or as otherwise proper for the circumstances.

Service will be restored at the request of the Customer PROVIDED:

- a) Restoration is approved verbally by Fire Department AND
- b) Restoration is approved verbally by OPU Gas Department where gas services exist, AND
- c) On site authorization is provided by a Journeyman Electrician who has inspected, and repaired if necessary, the premise wiring. This electrician shall be identified and shall furnish assurance that an issued Request for Electrical Inspection (Affidavit) will be provided to OPU by a licensed master electrician confirming the request for restored service.

In no event will service be restored if damage to OPU’s distribution outside the premises presents a hazard to persons or property.

208 LIABILITY

OPU does not engage in the practice of doing interior wiring on the Customer’s premises except for the installation and maintenance of its own property, and therefore, is not responsible for service beyond the point of delivery. OPU shall not be liable for damage to any Customer or to any third party resulting from the use of the service or from the presence of OPU appliances or equipment on the Customer’s premises.

The Customer is solely responsible for any accidents, fires, or failures resulting from the condition and use of his wiring installation or equipment.

209 SERVICE INTERRUPTIONS

OPU reserves the right to interrupt service at any time. Interruptions for maintenance and system improvements will be prearranged and advance notice will be given to the Customer whenever practical.

OPU will not be responsible for consequential damages resulting from service interruptions or fluctuations outside its control or from operations in response to abnormal system conditions. Customers requiring service reliability and/or stability exceeding OPU's normal service should consider uninterruptible power supplies, isolation transformers, power conditioners, redundant services, or other options to provide the level of service needed. OPU's Engineering staff is available to discuss such needs.

210 ACCESS

Employees of OPU shall have access at all reasonable hours to meters, service connections and other property owned by it which may be located on Customer's property. Access shall be provided for purposes of installation, maintenance, reading, checking, or removal if necessary. Failure to provide access shall result in termination of service until it has been provided.

211 CUSTOMER RESPONSIBILITY

Failure of the Customer to notify OPU in a timely manner of any planned alteration to electric service facilities or increased electrical load, and failure to comply with OPU's published rules, regulations, and rate schedules may result in delayed connections, interruption of service, or damage to equipment, for which OPU disclaims all responsibility.

212 REVISIONS OF REQUIREMENTS

All requirements stated or implied herein are subject to change at any time without prior notice. All revisions can be obtained from OPU's office.

213 DAMAGED UTILITY FACILITIES

At any time, if any segment of our facilities (including such things as poles, meters, or any other parts of our system) is damaged from any causes other than what is considered an "Act of God", OPU shall be reimbursed for our costs to repair. This cost should cover the full extent of the damages including labor involved in the repair, as well as material used, as well as any meters involved.

213.1 Cutting of Service Wires - No service shall be cut at any time by the Customer or contractor, and he shall not break the seal or remove the meter for any reason. OPU must be notified if this occurs, and we will make any adjustments necessary. If this rule is not complied with, suitable penalties shall be imposed on the one interfering with this service.

214 POSTING OF SIGNS ON UTILITY POLES

Attaching or hanging signs, posters, or other items to OPU's poles is strictly prohibited.

215 TREE PLANTING

If you plan to plant a tree at your expense near OPU's power lines, it is requested that you follow these guidelines:

- a) Please plant the tree no closer than 15 feet from underneath overhead electric wires to prevent outage problems in the future. This is also required by many of the utility easement terms.
- b) It is requested that a shorter variety of tree be planted in the vicinity of the power lines. OPU's Engineering staff at (507) 451-2480 can assist you in tree variety information.
- c) Please call Gopher State One-Call at 1-800-252-1166 before digging.

216 TREE TRIMMING POLICY

OPU easement rights allow for the construction, operation, and maintenance of its lines. This includes the right to enter the easement area to remove or trim trees and to remove or trim trees adjacent to the right-of-way that threaten the line due to their height or condition. OPU will take reasonable precautions to avoid damage to fences, crops, and other private property.

For reliability and safety, we strive to have our entire system trimmed every four to five years by rotation of affected areas. On all utility lines, we prune to provide ten feet of side clearance and no overhang dependent upon species. Work is based on OSHA 1910.269 requiring anyone trimming within ten feet of an energized conductor be trained in live line trimming procedures. In addition, we remove diseased, weakened, or leaning trees that pose a risk to our system or threaten to cause safety problems. Secondary service and street light wires are cleared if they are being pushed down, up, or out.

The effected customers will be contacted via door hangers in advance and not later than 24 hours prior to tree trimming work. The door hanger will include a local contact number so details of the work can be discussed.

217 METER TAMPERING

Refer to OPU Theft/Tamper of Utility Service policy #490.13, available online at www.owatonnautilities.com for specifics.

SECTION 300

RATES, CONNECTION CHARGES, AND CREDIT POLICY

301 RATE SCHEDULE CLASSIFICATION

Electric service is supplied to Customers under various rate schedule classifications as determined by the type of service, the amount of electric power supplied, and the purpose for which the electric service is to be used. Copies of OPU's rate schedules are available at OPU's Office and www.owatonnautilities.com.

302 PAYMENT

OPU will, insofar as possible, read all meters every month and bill the Customer for service used during the period. Payment of the bill is due by the date noted on the bill.

If the meter cannot be read during a billing period, or the reading seems erroneous, an estimate will be made for that billing period. Adjustments to bills resulting from inaccuracies in the meters will be handled in the manner described in Section 608, Meter Testing.

303 CUSTOMER CHARGES

303.1 Meter Fee – A charge to the Customer is assessed by OPU for each meter/service provided. The amount of this Customer charge will vary based on the type and number of services provided (refer to OPU's rate schedule for more information).

303.2 Service Connection Fee – For new services, refer to OPU's Line Extension Policy. There will be no charge for connections/reconnections of existing services, in good payment standing, during OPU's normal working hours (7:00 AM to 3:30 PM, Monday through Friday, excluding holidays). If connection must be made outside of normal working hours at the request of the Customer, it must be scheduled and approved through OPU's Engineering staff and a special connection charge may be assessed to the Customer.

304 SERVICE DISCONNECTION/RECONNECTION

304.1 Disconnections with Notice – OPU may disconnect a Customer's service, with notice, for any of the following reasons:

- a) Nonpayment of billings or issuance of non-negotiable check.
- b) Nonpayment of a deposit or other charges/fees.
- c) Failure to meet credit requirements.
- d) Failure to provide access to OPU owned metering equipment.

304.2 Disconnections without Notice – Without prior notice, OPU may disconnect a Customer’s service for any of the following reasons:

- a) A condition determined to be hazardous to the Customer, to other Customers, or to OPU.
- b) Unauthorized use of electricity, or equipment belonging to OPU.

304.3 Reconnections – In the event service has been disconnected for a non-payment, deposit, theft, or other credit cause, the Customer will be required to pay a reconnection fee to OPU before restoration of service. In the event that the service has been disconnected because of hazardous conditions on the Customer owned equipment or unauthorized use of electricity, the Customer will be required to submit proof of completion for all required inspections prior to service being restored. A schedule of fees is available from any OPU Customer Service Representative.

305 SERVICE DEPOSIT

305.1 New Customer Criteria – Generally, no deposit is required of a new customer. OPU, at its discretion, may require a deposit at the time the “Application for Service” is completed and signed. This will allow for OPU to obtain a copy of the Customer’s credit report. An evaluation of this report will determine if a deposit is needed. Should the Customer move to another location before they are eligible for a refund, the deposit will be transferred to the new location.

305.2 Current Customer Criteria – Should a Customer be disconnected for non-payment, OPU may require the Customer to pay a deposit if the Customer’s OPU payment history demonstrates the need.

305.3 Payment Method – The deposit payment is due the day service is connected. Payment may be made by cash, check or credit card.

305.4 Refund and Interest – Upon completion of twelve (12) consecutive monthly payments on time, the deposit will be refunded to the Customer. Interest is paid at the rate announced each year on December 15th by the Commissioner of Commerce for the following year.

305.5 Deposit Amounts – Generally, the following rate table will be followed for deposits:

<u>Type of Service</u>	<u>Residential</u>	<u>Small Business & Commercial</u>
Electric	\$ 40.00	\$130.00
Water	\$ 10.00	\$ 20.00
Gas	\$100.00	\$150.00

OPU, at its discretion, may require a deposit equal to the highest monthly billing expected during a calendar year.

306 SECURITY LIGHTING

Security lighting is available under its own rate schedule classification for those Customers requesting it.

DRAFT

SECTION 400

STANDARD SERVICES

401 GENERAL CHARACTERISTICS

This section describes the types of services offered to Customers under OPU's standard rate schedules. Electric service supplied by OPU is alternating current having a nominal frequency of 60 Hertz (cycles per second).

402 AVAILABILITY OF SERVICE

Although the types of service listed below are generally available through the area served by OPU, service of the type requested by a Customer may not be available at the location where such service is desired, and in certain cases may be available only through special contractual arrangements and at the expense of the Customer. **Each Customer will generally be allowed only one type of service and one point of delivery for each location. For redundant services, see Section 504.**

403 SECONDARY SERVICE VOLTAGE

The following types of secondary service are generally available to Customers served under OPU's standard rate schedules:

403.1 Single Phase Service - 120/240 Volt, 3-Wire, Grounded Neutral. Generally available where the total load is 167 kVA or less for pad-mounted primary service, or 50 kVA or less for pole-mounted primary service with an underground secondary in each case.

403.2 Three Phase Service – Generally available where facilities of adequate capacity are adjacent to the premises to be served. For loads where service desired by Customer is not adjacent to the premises to be serviced, special contract arrangements may be required prior to service being furnished.

- a) 208Y/120 Volt, 4-Wire, Grounded Neutral. Generally available where the total load is 75 kVA or greater for pad-mounted primary service, or 45 kVA or greater for pole-mounted primary service with an underground secondary in each case. The maximum size pad-mounted transformer that OPU will install is 500 kVA.
- b) 240/120 Volt, Delta, 4-Wire, Grounded Neutral. Available only where installed capacity exists.
- c) 480Y/277 Volt, 4-Wire, Grounded Neutral. Generally available where the total load is 75 kVA or greater for a pad-mounted primary service, or 75 kVA or greater for pole-mounted primary service with an underground secondary in each case. The maximum size pad-mounted transformer that OPU will install is 2500 kVA.

404 PRIMARY SERVICE VOLTAGES

Three-Phase, 12470Y/7200 Volt, 4-Wire, Grounded Neutral Service: Available only by special request. OPU reserves the right to deny a request for a primary voltage service. Where provided, the point of delivery will normally be the terminals of OPU's cable at the primary meter set.

DRAFT

SECTION 500

SPECIAL SERVICES

501 TEMPORARY SERVICE REQUIREMENTS

501.1 General – Temporary service is intended to be supplied at secondary voltages only to Customers for use during the construction of permanent facilities and before the permanent service can be installed. Temporary service for construction purposes may be obtained upon compliance with the provisions of the issued Request for Electrical Inspection (Affidavit) and payment of all applicable (**electric, water and gas**) project fees.

501.2 Address – The address of the location to be supplied with temporary service must be permanently displayed at the location before OPU will install the temporary service. All overhead and underground temporary services will be metered and billed under one of OPU's Standard Rate Schedules. OPU will furnish only the service drop or connect the lateral and the metering equipment.

501.3 Overhead Service – The Customer shall provide an approved meter socket with the necessary raceway and a suitable rigid support for attachment of the metering equipment and service drop or lateral. On all three phase temporary services, where required, the Customer shall also provide a suitable enclosure for installation of OPU's instrument transformers.

501.4 Underground Service – The Customer shall provide an approved meter socket with the necessary raceway and a suitable rigid support for attachment of the metering equipment. Where an underground service lateral is requested, the Customer is responsible for trenching and backfill from OPU's designed supply point (such as a service pedestal, pole or pad-mount transformer) to the meter socket location. The Customer shall also supply adequate cable (ampacity and length) for connection. On all three phase temporary services, where required, the Customer shall also provide a suitable enclosure for installation of OPU's instrument transformers.

501.5 Construction Safety - No connections will be made to any temporary service unless it conforms to current National Electric Code (NEC) requirements. All temporary services shall be equipped with ground fault circuit interrupter (GFCI) equipment per the National Electric Code (NEC) and OSHA requirements. Maintain all temporary services in a safe manner so that injury to persons shall not result from contact with it in any manner.

501.6 Installation Length – Service to any electrical installation for a period of less than two (2) years shall be considered as "temporary service". Any installation that remains in service longer than this timeframe must be changed to a permanent service installation when directed by OPU.

501.7 Fees - Temporary electrical services costs shall be in accordance with the following fee rates listed below. Quoted fees include all installation and removal costs plus any non-recoverable material costs.

Standard 120/240 volt single phase service connected directly from existing permanent OPU facilities (no wire spans, poles, transformers, etc.) = \$100

Temporary service requiring additional facility construction (added wire spans, poles, transformers, etc.) will be based on a time and material cost estimate. Contact OPU Engineering for costs.

502 SERVICES FOR UNUSUAL LOAD CHARACTERISTICS

The operation of Customer equipment having a relatively high load of short or intermittent duration, such as welders, compressor motors, elevators, and X-ray equipment, may cause serious fluctuations of voltage and interfere with the service being provided by OPU to other Customers. If such a load is anticipated, the Customer must consult with OPU and agree to install such protective devices as may be required so as not to cause damage to any of OPU's equipment or in any way inhibit service to other Customers. Additionally, special compensation may be required by OPU from the Customer in those cases where it is necessary for OPU to install special or larger facilities than would normally be required to provide satisfactory service.

503 EXCESS FACILITIES

OPU will normally size its electric facilities (primary cable and transformer) to serve the load projected by OPU. If a Customer desires OPU to install excess facilities, OPU must be advised as soon as possible so the feasibility of such a service can be determined. If OPU determines that excess facilities can and will be provided, the Customer will be required to reimburse OPU for the difference in cost between the standard service and the excess facilities, including all labor, materials, and overheads. A written agreement between the Customer and OPU shall also be executed at OPU's discretion.

504 REDUNDANT FACILITIES

OPU will normally provide one set of facilities (such as a set of primary cables and a transformer) to one point of service for each Customer. If a Customer requires redundant facilities (more than one set of facilities to the same point of service), OPU must be advised as soon as possible so the feasibility of such service can be determined. If OPU determines that redundant facilities can and will be provided, the Customer will be required to reimburse OPU for the entire cost of additional facilities, including all labor, materials, vehicle charges, and overheads. An agreement between the Customer and OPU may also be executed at OPU's discretion.

505 RELOCATION OR PROTECTION OF OPU FACILITIES

It is the responsibility of the Customer, when appropriate, to arrange for the relocation and/or protection of OPU facilities. Any intended relocation or protection of OPU facilities must be reviewed with and approved by OPU in advance. The cost of any change or relocation of OPU facilities for the benefit only of the Customer, and which has been initiated by the Customer, shall be borne solely by the Customer. A deposit by the Customer may also be required before the changes are made. OPU will bear costs to the extent that a change or relocation benefits OPU. The Customer shall not be required to pay for changes necessitated through public improvements by the City, County or State. The Customer shall not paint or otherwise modify the appearance of any OPU owned equipment or facilities without approval from OPU.

506 REWIRING OR UPGRADING EXISTING FACILITIES

The Customer or electrical contractor shall contact OPU when it is necessary to rewire or upgrade an existing electric service. All OPU Electric Service Rules & Regulations must be followed. The Customer shall be responsible for maintaining the same phase rotation for 3-phase rewires. Customers shall not be allowed to convert an existing underground electric service to an overhead service.

SECTION 600

METERS

600 GENERAL

This section covers the installation of meters and associated equipment such as current and potential transformers for both overhead and underground services. Further description of OPU requirements for both overhead and underground services is covered in other sections of this booklet. The requirements contained in this section are for services rated 600 volts or less. When services are required at primary voltage (such as 12470Y/7200 volts), the metering requirements and equipment will be determined on an individual basis.

600.1 Meter Bypass – All new or rewired residential or commercial services must have an approved lever operated bypass meter socket with lever actuated positive bypass mechanism, which will also provide clamping pressure on the meter blade. Refer to Section 613.3 for approved bypass meter sockets. Any new or rewired service without an approved bypass socket will not be energized.

601 RESPONSIBILITIES FOR PROVIDING METERING EQUIPMENT

OPU supplies and installs, at its' own expense, all meters and such accessories as are required for billing purposes. This includes all revenue meters, current and potential transformers, phase-shifting transformers, test switches (required for 3Ø metering where current transformer are used), and color-coded meter wiring. The Customer or his representative must purchase sockets for instrument transformer rated meters directly from OPU. It shall be the responsibility of the electrical contractor or the Customer to secure all other meter socket bases, or meter centers for multiple meter installations, which are approved by OPU for the intended purpose (See Section 1200, Exhibit 5). OPU will energize only one set of metering equipment under each contract or application for one class of service.

602 LOCATION OF METERS

Meter locations will be agreed upon by representatives of the Customer and OPU, subject to final approval by OPU.

602.1 Clearances – Meters shall be located such that there is a minimum of three (3) feet of unobstructed space in front and one (1) foot on all sides. Meters shall not be located where they are subject to corrosive fumes, dust, vibration or physical damage. Outdoor meters shall not be located in carports, under porches whether open or enclosed, or along walkways or driveways where they might create a hazard to people or be subject to damage by passing objects.

602.2 Accessibility – Meter locations shall not be hazardous or cause inconvenience to employees of OPU when installing, maintaining, or reading the meters. OPU personnel shall have direct and unobstructed access to OPU’s metering equipment at all times.

602.3 Industrial and Commercial - Meters for industrial and commercial services shall be located outdoors.

602.4 Height Limits - All meters located outdoors on residential or commercial services where the meter is mounted on a permanent structure, shall have a maximum installation height of 5’-6” and a minimum installation height of 4’-6” from final grade to the center of the meter. A typical residential underground metering arrangement is shown in Section 1200, Exhibit 1.

602.5 Residential – Residential meter installations shall comply with the following requirements:

- a) All new services must have the electric meter located outdoors.
- b) Existing Customers where the meter is located inside the home shall relocate the meter outdoors if the service is upgraded.

602.6 Multi-Family Dwelling – Where more than one meter is installed (typical for apartment complexes), meters shall be grouped outdoors at a point accessible at all times to each Customer and to OPU employees.

Exceptions:

- a) *Multi-family dwellings that have 24 meters or more may request in writing to locate the meters inside as long as they are grouped at one location and accessible at all times to each Customer and OPU personnel.*
- b) *Multi-family dwellings where the building has over three (3) occupied stories fully above grade may request permission in writing to allow the installation of grouped metering panels in multiple locations. These locations should be minimized and typically would only be allowed on every 3rd story of the building.*

In all cases where multi-metering panels with stacked meter sockets are used, the maximum height to the center of the top meter shall be not more than 6’-0” and the minimum height to the center of the bottom meter shall be not less 2’-0” indoors and 3’-0” outdoors. An approved manual bypass is required on all meter sockets. Individual apartment disconnects must be connected on the load side of the meter. If the service voltage is 120/208 volts, a fifth terminal located at the 9 o’clock position is required in the socket and must be connected to the service neutral in accordance with the National Electric Code (refer to Section 1200, Exhibit 5). Only one meter may be installed under one socket cover in multi-metering panels.

602.7 Mobile Homes - OPU will individually meter each mobile home located in a mobile home court or addition to a mobile home court. Resale of metered electrical energy by the court owner will not be permitted in these facilities. Individual meter pedestals, with bypass

sockets, shall be provided by the Customer or his representative. Maintenance and repair of the meter pedestal is the responsibility of the Customer. A typical mobile home metering arrangement is shown in Section 1200, Exhibit 3.

602.8 Commercial Multi-Metering Panels - All commercial multi-metering panels used in shopping centers, spec. buildings, and multi-commercial tenant buildings shall have a maximum of four (4) meter sockets per vertical stack. In all cases, the maximum height to the center of the top meter shall be 6'-0" and the minimum height to the center of the bottom meter shall be 1'-0" indoors, and 3'-0" outdoors. An approved lever bypass is required on all meter sockets and each individual unit disconnect shall only be connected to the load side of the meter. Each individual meter socket shall have a barrier to isolate the Customer's disconnect switch and wiring from the metering area. Only one meter may be installed under one socket cover. A system neutral is required to each 5 and 7 terminal meter socket. The minimum wire size for this neutral shall be #14 AWG, or larger as required by the National Electric Code.

Exception:

- a) *In situations where the building has over three (3) occupied stories fully above grade, the Customer may request in writing permission to allow the installation of grouped metering panels in multiple locations. These locations should be minimized and typically would only be allowed on every 3rd story of the building.*

603 GROUPED METERS

In installations requiring more than one meter, the meters shall be grouped and suitably connected such that a meter serves no more than one Customer. The height limits stated previously also pertain to grouped meters where practicable. If deemed necessary by the space available, the meters may be stacked in an orderly fashion. Any dwelling with more than one Customer living therein must be easily accessible to all tenants and to OPU personnel. There shall be an approved type of disconnecting means for each meter, which is lockable in some way to prevent reconnection by other than OPU personnel. A typical multiple metering arrangement is shown in Section 1200, Exhibit 4.

604 METER IDENTIFICATION

If more than one meter is required for a building, each meter socket shall be identified and permanently designated in a suitable manner indicating the particular Customer served. Each circuit shall be carefully traced and rechecked by the Customer or contractor to ensure against errors in wiring, whereby one Customer might obtain service through the meter serving another Customer. This is especially important when the wiring is concealed.

Electric service shall not be energized if meter sockets are not identified. It will be the building owner or electrical contractor's responsibility to correct any errors due to

misidentification of meter sockets. OPU reserves the right to charge the building owner and/or electrical contractor for actual costs incurred by OPU to make corrections.

605 METER MOUNTING

605.1 Outdoor Meters and Meter Mounting Devices – Outdoor meters and meter mounting devices shall be mounted securely on permanent structures such as houses, garages, and other buildings. Mounting of meters shall be done at four corners to permit removal by OPU personnel during siding or re-siding of the house in the future. Where outdoor meters are installed on surfaces that prevent installation of the meter-mounting device in an exact vertical plane, a meter board must be installed or the surface modified in such a manner that the meter-mounting device can be installed vertically.

605.2 New Customer Preferred Meter Location(s) – The preferred meter location for new Customer hook-ups shall be as follows:

- a) For new hook-ups fed from transformers or secondary pedestals located within front lot line easements, the meter shall be located within ten (10) feet of the front end of the building (house or attached garage) on the side nearest to the transformer or secondary pedestal.
- b) For new hook-ups fed from poles, transformers or secondary pedestals located within rear lot line easements, the meter shall be located within ten (10) feet of the rear of the building (house or attached garage) on the side nearest the pole, transformer, or secondary pedestal.

605.3 Upgraded or Rewired Service Location(s) – All indoor meter locations scheduled for rewiring or service upgrades shall be relocated outdoors with locations agreed upon between Customer, electrical contractor, and OPU personnel with final approval by OPU. OPU reserves the right to refuse to energize service if these requirements have not been met.

605.4 Indoor Meters Where Permitted – Indoor meters, where permitted, shall be mounted in accordance with the preceding requirements of this section and shall be located as close as possible to the point where service enters the building. Indoor metering equipment shall be mounted securely in a vertical plane on permanent structures in a location free from moisture, high temperature, vibration, dust, or dirt.

606 METER CONNECTIONS

The Customer shall provide the necessary wiring for the meter set with the wiring so arranged that the line (supply) side can be connected to the top terminals of the socket and the load side to the bottom terminals. All conductors shall extend into the meter socket and shall be of equal length and at a minimum distance equal to the length of the socket trough. All neutral conductors must be insulated. For underground services, the line side neutral wire is to be identified in accordance with the National Electrical Code (NEC). There

should be sufficient slack left in the underground cables to make up for any ground shifting due to settling or extreme cold.

607 WIRING RESTRICTIONS ON METERS AND METERING SETS

No Customer wiring is permitted to be connected to the metering, secondary wiring or under the terminals of the meter. No part of the metering set may be used as a junction box for the Customer's wiring.

608 METER TESTING

608.1 - Any Customer, who believes that a meter is failing to register properly the use of electricity, may request a meter check. OPU will test the meter using standard calibration equipment and generally accepted test procedures within a reasonable period of time. Customers who request additional meter tests within a 12 (twelve)-month period may be charged for the additional tests at a standard fee.

608.2 - Whenever a watt-hour meter is found upon test to have an average error of more than two percent (2%) from one hundred percent (100%) or a demand meter more than one and one-half percent (1.5%) from one hundred percent (100%), a recalculation of bills for service will be made on the basis that the meter should be one hundred percent (100%) accurate with respect to a working test standard.

608.3 – If the period of inaccuracy cannot be determined, it will be assumed that the metering equipment has become inaccurate at a uniform rate since it was installed or last tested unless there is a valid reason to use another method. Recalculation of bills is based upon OPU Commission Policy for adjustments of Customer accounts.

608.4 - When the average error cannot be determined by test due to complete failure of all or part of the metering equipment, then an estimate of the quantity of energy consumed based upon available data will be used to determine the adjusted bills.

609 METER SEALS

All connections to OPU service equipment shall be made by OPU personnel only.

Unauthorized connections to or tampering with any OPU meter, associated equipment or meter seals, or indications or evidence thereof subjects the Customer to immediate discontinuance of service, prosecution under the laws of Minnesota, adjustment of prior bills for services rendered, and reimbursement to OPU for all extra expense incurred on the account. In addition, when the unauthorized connections or tampering involve an inside meter, the Customer shall, at his own expense, relocate all service equipment and metering facilities outside the building.

INSTRUMENT TRANSFORMER METER INSTALLATIONS

610.1 Where Required - When the ampacity of the service, either single-phase or three-phase, has a total calculated load of 320 amps or greater, it will be necessary for OPU to use instrument transformers in the metering installation. These instrument transformers will be furnished at a cost to the customer and installed by OPU within the Customer furnished Instrument Transformer cabinet.

610.2 Secondary Metering Instrument Transformer Cabinet – Cabinet shall be furnished and installed by the Customer. This includes all services, either overhead or underground. All cabinets must be certified and labeled, approved by OPU personnel and meet all National Electric Code (NEC) requirements prior to installation. Cabinets must conform to the following:

- a) Cabinets must be UL approved and be the correct NEMA class for the area environment in which it is installed
- b) The minimum cabinet size is to be 24 inches wide, 24 inches high, and 10 inches deep
- c) The door must have a single closure with provisions for locking with a standard padlock through the handle.
- d) Cabinet must be hinged on the right or left side only.
- e) Cabinet shall not be used as a junction box or service connection cabinet.
- f) Only OPU metering transformers may be contained therein.
- g) Cabinet must accept bar-type current transformers.
- h) Customer is required to label the line side and load side of the conductors within the instrument transformer cabinet.

All services that require current transformers to be used will require the Customer or electrical contractor to purchase a meter socket from the OPU metering department. Contact the OPU metering department to obtain the proper socket and pricing.

610.3 Conduit Requirements - The Customer must furnish and install the following conduits when an instrument transformer cabinet is used:

- a) A 1-inch conduit from the instrument transformer cabinet location to a meter socket location approved by OPU. The conduit shall not contain more than two (2) 90° bends and a pull wire shall be installed in the conduit. Conduit run shall not exceed 25 feet, except by special permission.
- b) A ¾-inch or greater conduit shall be installed from the meter socket location to a location inside the building (**Industrial or Commercial meter sets only**). This conduit would preferably be run to and terminate inside the phone room of the building or stubbed adjacent to the phone punch down panel. Contact OPU for cable specification and installation requirements for this conduit.

610.4 Underground Service from Pad Mounted Transformers -

Where service is underground from a pad-mounted transformer, instrument transformers are to be mounted in an approved instrument transformer cabinet. The location of the instrument transformer cabinet must be approved by OPU during installation.

610.5 Overhead Services - Where service is provided by overhead service drops, an approved outdoor instrument transformer cabinet will be required. Location of transformer cabinet will have final approval by OPU before installation. (No open air CT's or PT's will be allowed).

610.6 Indoor Mounted Instrument Transformers - Instrument transformers installed indoors must have a service size of 1200 amps or greater, be installed inside the Customer's switchgear in a compartment designated for instrument transformers only, and have prior approval from OPU.

610.7 Outdoor Primary Metering Equipment – Allowable only by special permission. Contact OPU Engineering for approval.

611 SELF-CONTAINED METER INSTALLATIONS

611.1 Single Phase Commercial - OPU will install self-contained meters (meters without instrument transformers) on commercial services where the service rating is 400 amps or less. Where such metering is to be used, the Customer shall provide a lever-operated bypassing socket. Such sockets permit a continuation of service upon removal of the meter for testing or maintenance. If a level-operated bypass socket is not installed, the service will not be energized.

611.2 Three Phase Commercial - OPU will install self-contained meters (meters without instrument transformers) on commercial services where the service rating is 400 amps or less. Where such metering is to be used, the Customer shall provide a lever-operated bypassing socket. Such sockets permit a continuation of service upon removal of the meter for testing or maintenance. If a lever-operated bypass socket is not installed, the service will not be energized.

611.3 Minimum Rating – Commercial self-contained meter sockets must be rated continuous 200 amperes, minimum.

612 MASTER METERING INSTALLATIONS

612.1 - All new residential units will be individually metered.

Exception Provided in Minnesota Rule 326B.106 Subd. 12:

Buildings intended for occupancy primarily by persons who are 62 years of age or older or disabled, supportive housing, or buildings that contain a majority of units not equipped with complete kitchen facilities, shall be exempt from the provisions of this subdivision. For

purposes of this section, "supportive housing" means housing made available to individuals and families with multiple barriers to obtaining and maintaining housing, including those who are formerly homeless or at risk of homelessness and those who have a mental illness, substance abuse disorder, debilitating disease, or a combination of these conditions."

A Customer claiming the above exception above takes all legal responsibility for proving the exemption for the life of their building. Any Customer claiming the exception above must provide OPU, in writing, a statement that they are claiming an exception under Minnesota Rule 326B.106 Subd. 12 and why they feel their building meets the requirements for an exception. OPU does not determine the validity of the claimed exception and this required filing is for OPU's documentation only.

612.2 - All new commercial or industrial units will be individually metered.

Exceptions:

- a) *Where the construction of a building or installation is such that individual service conductors and disconnects are not required by provisions of applicable building codes.*
- b) *Where the building or installation owner can demonstrate conclusively that the cost to accommodate individual metering exceeds the long-run cost benefit to the individual occupants.*

All written requests for exception must be approved by OPU's Engineering Department.

612.3 - Existing master metered buildings or installations will be reviewed if:

- a) Additional units are added or the nature of the existing units is substantially altered, and
- b) If the occupants of the units are responsible for paying for a portion of the electric power and energy used in these units.

The continuation of master metering in existing buildings or installations will be prohibited unless the owner demonstrates conclusively that the cost to accommodate individual metering exceeds the long-run cost benefit to the individual occupants.

612.4 - Individual meters will be installed, owned, maintained, and read by OPU. Submetering by others for the purpose of charging individual occupants based on measured use must be in accordance with statutory requirements. Submetering by others for information purposes or to control the use of electric power for energy is permitted.

613 SELF-CONTAINED METER SOCKETS

613.1 General Requirements - Meter sockets installed for self-contained meters must be approved by OPU prior to installation. Meter installations made with unapproved sockets

will not be energized. Services energized with unapproved sockets will be subject to disconnection until the correct socket is installed.

613.2 Customer Furnished - Meter sockets for single phase self-contained metering up to 320 amps and for three phase self-contained metering up to 320 amps are to be furnished and installed by the Customer or electrical contractor. 320 amp meter sockets require an approved lever actuated positive bypass mechanism which will also provide clamping pressure on the meter blades.

613.3 Approved Bypass - Currently the Ladis and Gyr (HQ), Milbank (HD 200 Series), Thomas & Bells/Anchor (TB Series), and Square D (HD) bypasses are approved. Any other bypass socket must have approval from OPU prior to installation.

614 INSTRUMENT TRANSFORMER METER SOCKETS

614.1 OPU Furnished - Meter sockets for instrument rated meters (Single and three phase services over 400 amps, where current transformers are used) must be purchased from OPU. Customer will install the current transformers in the Customer furnished Instrument Transformer cabinet. Contact OPU's Metering Department to obtain the proper socket.

615 SERVICE AT 480 VOLTS

Any meter socket installed on a 480-volt service must conform to the following requirements:

- a) Have a flash shield provided over the jaws
- b) Have an approved bypass mechanism installed
- c) Clearly labeled "480Y/277" both on the inside and outside of the socket
- d) Has a minimum ampacity rating of 200 amperes

616 LOCATION OF HIGH-LEG IN METER SOCKET ON 240/120 VOLT, 3-PHASE SERVICES

The conductor with the higher voltage to ground must be connected to the terminal on the right side. The high-leg conductor must be identified as required by the National Electric Code (NEC). Meter sockets with the high-leg in the wrong position will not be energized. Incorrectly wired sockets will be subject to disconnection until wiring is corrected.

617 REMOVING OPU SEALS AND METERS

Disconnection of OPU metering equipment and cutting of seals is not allowed.

618 CUSTOMER GENERATION

Where a Customer intends to operate any type of electric generator, photovoltaic array, wind generator, or similar equipment interconnected with OPU's system, special service

and metering requirements must be satisfied. Contact OPU for details prior to interconnecting any generation equipment.

619 PROPER GROUNDING/BONDING OF METER SOCKETS & SERVICES

Service equipment and enclosures may need to carry heavy fault currents in the event of a ground-fault. For this reason, it is imperative that meter sockets and conduits be adequately bonded to the neutral and to the ground. Bonding is to be done by threaded couplings and threaded bosses in a rigid metal conduit system where the joints will be made up wrench tight. Locknuts and bushings do not fulfill the requirement of bonding at service equipment. Grounding bushing (with bonding jumpers), bonding locknuts, threaded conduit hubs, or other means are approved (Refer to National Electric Code (NEC) Article 250.66). All metering conduits and sockets must be properly grounded. If PVC conduits are used, grounding conductors must be provided and installed by the Customer or electrical contractor in accordance with the National Electric Code (NEC). Electric services will not be connected if improperly grounded/bonded upon inspection.

619.1 Neutral for 5 and 7 Terminal Sockets - A system neutral is required to each 5 and 7 terminal socket. The minimum conductor size is #14 AWG wire. Conductor should be sized in accordance with the National Electric Code.

620 CUSTOMER DISCONNECT SWITCH

Individual Customer disconnect switches shall be connected on the load side of the meter. No customer devices, e.g. surge suppressors, load management equipment, etc., may be installed on the line side of the meter.

Each non-residential Customer must have a separate securable disconnect accessible to OPU at all times. If the building is a multi-tenant building, each non-residential Customer must have a separate securable disconnect. The securable disconnect shall be labeled and mounted adjacent to the meter location.

621 SPECIAL SOCKETS

All special sockets, such as apartment panels, recessed, mobile home parks, socket and switch, or socket and transfer, must have OPU's approval prior to installation.

622 OPU OWNED EQUIPMENT

Any metering equipment furnished by OPU, such as meters, instruments transformers, relays, totalizers, test switches, etc., remain the property of OPU. If the equipment has to be removed or disconnected for any reasons, please call OPU so that the equipment can be picked up.

623 TEMPORARY LOOSENING OF CUSTOMER OWNED METER SOCKETS BY OPU PERSONNEL

OPU will temporarily loosen a meter socket from the home or premise walls for siding installation and/or repair. If at any time safety is a concern, OPU will have the service de-energized to perform the work. The Customer or contractor shall contact OPU one (1) business day in advance to schedule temporary loosening of the meter socket for siding purposes.

624 CLEARANCES FROM GAS METERS

OPU requires a minimum of 3 feet clearance from the gas meter to electric meter socket, electric disconnect switch, or any sources or ignition. Refer to Section 1200, Exhibit 1 for a typical underground residential metering arrangement.

DRAFT

SECTION 700

CUSTOMER UTILIZATION EQUIPMENT

The Customer's service entrance and utilization equipment shall be installed in accordance with all local, state, and National Electrical Code (NEC) requirements. It is the intent of this section to provide the Customer with recommendations concerning factors that can affect both OPU and the Customer in the selection, installation, maintenance, and operation of the Customer's utilization equipment. If concerns arise that are not covered in this section, please contact OPU Engineering for assistance.

701 PROTECTION OF CUSTOMER EQUIPMENT

The customer is advised to provide adequate protection against the effects of outages or voltage spikes in accordance with the National Electric Code (NEC) or other pertinent sources of information for all types of motors and other equipment. Equipment that should be protected includes, but is not limited to:

- (1) Motors
- (2) Computers
- (3) Electronic Equipment
- (4) Equipment in which computers or electronics form an integral operating part

Equipment should be protected under all conditions, including:

- (1) Overload
- (2) Voltage Loss
- (3) High or low voltage
- (4) Phase loss (e.g. single phasing on polyphase motors)
- (5) Re-establishment of service after any of the foregoing
- (6) Phase reversal
- (7) Motors that cannot be subjected to full voltage on starting
- (8) Harmonics or wave form irregularities

Failure to provide such protection may result in needless damage to equipment and the expense of delay and repair.

Sensitive electronics, such as microprocessor-based home electronics and business computers, are susceptible to damage due to voltage spikes or surges. Before any microprocessor-based electronics are installed:

- (1) Wiring practices that meet manufacturer specifications need to be assured (e.g. proper grounding and dedicated circuits are important)
- (2) Consideration should be given to installation of transient voltage surge suppression
 - a) At the main service entrance

- b) At the point of use
- (3) An uninterrupted power supply (battery backup) should be considered if a momentary voltage dip or outage would cause loss of data

702 MOTOR STARTING CURRENTS

702.1 General – Typically, all motors require a starting current substantially greater than their normal running current. Where starting currents are excessive, an abnormal drop in supply voltage will result. In order to minimize the unfavorable effects of such voltage drops, it is essential that the Customer's motors do not exceed the allowable starting characteristics as shown in Table 430-251(A and B) of the National Electric Code (NEC).

Customers planning to install any motor larger than 5 HP single phase or 25 HP three phase, must contact OPU for special permission. OPU may require a reduced voltage starter or a Variable Frequency Drive (VFD). Motor installations that cause power quality problems for other Customers shall be corrected at the owner's expense.

702.2 Voltage Flicker – OPU uses IEEE Standard 141 (IEEE Red Book) as a guideline for the level of allowable flicker. Customers are not allowed to start any load on OPU's system that produces unacceptable levels of flicker which affect other Customers. Customers are responsible for correcting unacceptable flicker problems in a timely manner when notified by OPU.

703 POWER FACTOR

In order to improve the efficiency of OPU's distribution system, the Customer's utilization equipment shall maintain an average power factor as close to unity as possible.

For new services, it is suggested that the Customer's utilization equipment be designed for operation at high power factor or with capacitors that are switched on and off with the equipment. See Section 1500, Exhibit 14 for correcting Customer's power factor.

704 FAULT CURRENTS

The Customer's service equipment and other devices shall be adequate to withstand and interrupt the maximum available fault current. For single-family residences with service equipment rated 200 amperes maximum and 120/240 volts, single phase, equipment shall have a minimum interrupting rate of 10,000 amperes symmetrical and other equipment shall be braced to withstand that minimum value. Please refer to Sections 1100 and 1200, Exhibit 13 for additional information.

705 WIRING ADEQUACY

The National Electrical Code (NEC) specifies the adequacy of wiring with respect to safety, but such installations may not be efficient, convenient, or adequate for good service of future expansion of electrical use. In many instances, the installation of wiring capacity greater than minimum code requirements is strongly recommended.

706 CUSTOMER-OWNED GENERATING EQUIPMENT

Unless authorized by written agreement, electric generating equipment installed by the Customer shall not be interconnected or operated in parallel with OPU's system. The Customer shall own, install, operate, and maintain electrical interlocking equipment which will prevent parallel operation and such equipment shall be approved by OPU prior to installation. Please contact OPU for specific requirements relating to generation installations designed to operate in parallel with OPU's distribution system (e.g. solar, wind, etc.)

707 CUSTOMER'S OBLIGATIONS

707.1 Increased Load – In the event the Customer desires to increase load materially, such as adding electric heat, increased motor loads, etc., they shall give OPU sufficient advance notice, so that OPU may provide added facilities if necessary. If the Customer fails to notify OPU and OPU's equipment is damaged as a result of such increased load, the Customer shall reimburse and make payment to OPU for all such damages.

707.2 Balancing of Load – Except in the case of three-phase four-wire delta services, the current unbalance in three-phase services shall not exceed 10 percent of the current that would be required at maximum load under balanced conditions.

708 TOTAL HARMONIC DISTORTION (THD)

708.1 Nonlinear Load Requirements - The application of any nonlinear load by the Customer (e.g., static power converters, arc furnaces, adjustable speed drive systems, etc.) shall not cause voltage and/or current Total Harmonic Distortion (THD) levels greater than industry accepted levels on OPU's electric system at the point of power delivery to the Customer's facility. Please refer to IEEE Standard 519-1992, "IEEE Recommended Practices and Requirements for Harmonic Control in Electric Power Systems."

708.2 Nonlinear Load Disclosure - The Customer shall disclose to OPU all nonlinear loads prior to connection. OPU may test the Customer's load to determine the THD levels.

708.3 Nonlinear Load Responsibilities - It shall be the responsibility of the Customer to assure that the THD requirements are met, including the purchase of necessary filtering equipment. Any load found not in compliance with this policy shall be corrected

immediately by the Customer at the Customer's expense. If not corrected, OPU may disconnect service to the Customer's facility.

708.4 Nonlinear Load Damages - The Customer shall be liable for all damages, losses, claims, costs, expenses and liabilities of any kind or nature arising out of, caused by, or in any way connected with the application by the Customer of any nonlinear load operating with maximum THD levels in excess of the values stated in Section 708.1 above. The Customer shall hold harmless and indemnify OPU from and against any claims, losses, costs of investigation, expenses, reasonable attorney's fees, damages and liabilities of any kind or nature arising out of, caused by, or in any way connected with the application by the Customer of any nonlinear load operating with maximum THD levels in excess of the values stated in Section 708.1 above.

709 CARRIER CURRENT - CUSTOMER RESPONSIBILITIES AND LIMITATIONS

OPU reserves the right to use carrier frequency signals on its system for communication, system operation and equipment control, and shall not be held liable for any resulting damages. In general, signals of this nature will not interfere with Customer processes. Customers should install protective equipment if such frequencies might damage or interfere with their apparatus. Contact OPU Engineering if you have specific concerns.

Customer-owned carrier current transmission, broadcasting or control, are not allowed on OPU's system.

SECTION 800

OVERHEAD SECONDARY SERVICES

OPU will supply overhead secondary service (600 volts or less), in areas where overhead facilities are available, at the voltages and under the conditions specified in other sections of this publication. The service entrance location will be specified by OPU. This section includes information on distribution transformer size, overhead service drop, and connections to the Customer's premises or equipment. Metering and customer equipment requirements are covered in other sections of this publication. The requirements of this section apply to all residential, commercial, and industrial customers.

801 MAXIMUM TRANSFORMER SIZE

801.1 – The maximum overhead transformer size installed by OPU will be either one 50 kVA transformer for a single-phase application or three 50 kVA transformers for multiphase applications. If a larger transformer size is required for a particular application, it shall be a pad-mounted type.

801.2 – One or more secondary services may be supplied from a transformer; the number of services from a transformer shall be determined by OPU depending upon the application.

802 SERVICE DROP CONDUCTORS

802.1 – The service drop for new services will be twisted wire triplex (3 wires) or quadruplex (4 wires) configuration from the distribution system to the point of attachment on the customer's premises.

802.2 – Existing services may either be a twisted wire or open wire configuration. If necessary for various reasons, OPU may change a service from an open wire to a twisted wire configuration.

803 OVERHEAD CLEARANCES

803.1 – The service drop must be so located that the minimum clearance as specified in the latest editions of the National Electrical Code (NEC) and the National Electric Safety Code (NESC) are maintained. An illustration of the clearances required is shown in Section 1200, Exhibit 4. *It is strongly recommended that the Customer contact OPU's Engineering Department if the service is going to pass over a roof, balcony/deck, or within 5 feet of a window/door for additional clearance information. OPU will not energize an electric service with an observed clearance violation.*

803.2 – Service drop conductors shall not be installed above a hot tub/swimming pool or surrounding area extending 10 feet horizontally from the pool edge, diving structure, observation stands, towers or platforms.

804 POINT OF ATTACHMENT

804.1 – A solid point of attachment for supporting the service drop on the building shall be provided by the Customer at a point, which will comply with previously stated clearances. Where the required heights and clearances cannot be maintained by a point of attachment on the building, the Customer shall provide a service mast which is of a permanent nature and of sufficient strength to support the service drop at the required minimum clearance. Typical building attachment and service mast installations are shown in Section 1200, Exhibits 7 and 8, respectively. In such an installation, 2-inch or larger galvanized iron conduit or 3-inch or larger rigid aluminum conduit shall be used. OPU reserves the right to decline to connect its service drop to an extension support, which, in its judgment, constitutes a hazard to life or property.

804.2 – If it is necessary that this service extend greater than 30" above the roof, the pipe size shall be increased accordingly, to give suitable strength to support OPU's service connection. If the conduit is not increased in size, a tie to the building must be supplied by the Customer to support the service wires.

805 SERVICE ENTRANCE

805.1 – The Customer's service entrance wiring shall terminate at a point so located that the service drop from the supply lines will not interfere with windows, doors, awnings, drainpipes, or other parts of the building or other obstructions so that only one bracket is required.

805.2 – Customer's portion of the service shall consist of conduit, a weather head, and wire, furnished by the Customer and attached to their building. Tails shall be left on the customer service wires extending a minimum of three (3) feet beyond the weather head. The neutral wire shall be identified and shall be continuous (no cut) from the weather head to the entrance switch (unless otherwise approved by OPU).

SECTION 900

UNDERGROUND SERVICES

901 NEW RESIDENTIAL DEVELOPMENTS

OPU will designate a point of delivery for the connection of the Customer's secondary underground service. The point of delivery may be a service pedestal, junction box, or the terminals of a pad-mounted transformer. In general, OPU will install, own, operate, and maintain all facilities on the source side of the point of delivery, including the junction enclosure and connections; the Customer will install, own, operate, and maintain all secondary cables, conduit, and related service equipment specified in other sections of this publication on the load side of the point of delivery (typically the meter socket).

Points of delivery will be located within OPU's easement area along or near a front or rear property line unless it is necessary or desirable to designate locations which are closer to the metering point(s).

Additional information regarding OPU and Customer responsibilities for URD installations is provided in Section 1200, Exhibit 9.

902 RESIDENTIAL UNDERGROUNDING IN OVERHEAD AREAS

902.1 – Customers residing in residential zones presently served by overhead lines may request underground electric service. Customers intending to relocate, upgrade, or replace an existing overhead service may request underground service. In either situation, the Customer shall own, operate, and maintain the facilities specified in Section 901 above.

903 UNDERGROUND SERVICE TO DWELLINGS

903.1 – The minimum conductor size for 120/240 volt, 3-wire, single-phase, dwelling service, service entrance, service lateral or service feeders shall be 1/0 AWG.

A slack (frost) loop to provide for ground movement shall be provided on all service conductors at each riser location, meter location, and joint location.

Service entrance conductors passing below existing or proposed paved areas or above grade structures such as decks, shall be installed in minimum 2 inch PVC Conduit, Schedule 40 PVC duct of the appropriate size. Conduit installed for this purpose shall be furnished by the electrical contractor or Customer.

Frost sleeve will be provided at the dwelling line side riser. The frost sleeve is buried at grade level to move with the ground frost changes and not the 2-inch line side service lateral conduit.

903.2 - Underground service entrance conductors shall be installed a minimum of twenty-four (24) inches and a maximum of thirty-six (36) inches below the final grade. Conductors shall be installed in as straight line as possible from power source (pole or secondary pedestal) to the meter location. Conductor trench is provided by the electrical contractor or Customer and shall be back-filled and compacted with a good fill material, free of rocks and foreign material to prevent damage to the cable.

904 UNDERGROUND SERVICE TO COMMERCIAL AND INDUSTRIAL CUSTOMERS

904.1 – OPU requires the underground installation of primary and secondary distribution service to new commercial and industrial structures.

904.2 – OPU will designate a point of delivery for the connection of the Customer's secondary underground service lateral. The point of delivery will normally be the secondary terminals of a pad-mounted transformer placed at a mutually agreeable location on the Customer's property, as close as practicable to the metering point.

904.3– OPU will install, own, operate, and maintain the primary underground cable, the distribution transformer, and the secondary connections at the distribution transformer.

904.4 – If underground primary distribution facilities are located on the Customer's property, the Customer or their electrical contractor shall provide the conduit from a designated point of interconnection to the distribution transformer.

904.5 – If overhead main distribution facilities are located on or adjacent to the Customer's property, the Customer shall provide conduit from the riser pole, including the long sweep elbows, to the pad-mounted distribution transformer. The conduit at the riser pole shall be stubbed up above finished grade a minimum of 8 feet for connection and extension by OPU.

904.6 – The Customer shall install, own and maintain a concrete transformer pad constructed to OPU specifications. If the transformer is located in an area where it may be subject to physical damage (e.g. from vehicular traffic), OPU may require the customer to furnish and install an approved means of protection (such as bollards).

904.7 – The Customer shall install, own, and maintain all secondary cables, connectors, and conduits from the transformer (either pole or pad-mounted) or CT cabinet (where installed) location to the building service entrance.

OPU must approve the design of all secondary bus duct and cable bus designs. The installation will be inspected by OPU and the secondary connections to the transformer will be made by OPU. It is the Customer's responsibility to coordinate with and provide the necessary information to OPU to assure that adequate connections are made at the secondary terminals of the transformer.

904.8 – OPU will furnish and install the meter set in accordance with the requirements of Section 600.

904.9 – The maximum number of secondary connections available shall be:

Single Phase: Six (6) 350 MCM conductors per phase

Three Phase:

TRANSFORMER SIZE	# OF CONDUCTORS PER PHASE
45 KVA	3
75 KVA to 500kVA	6
750kVA to 2500kVA	10

The maximum size secondary conductor to be installed in a 3-phase transformer is 500 MCM. Parallel conductors shall be of identical wire size. Contact OPU's Engineering Department if more or larger conductors are required.

Any service requiring more conductors per phase than listed above must utilize a Customer-provided secondary connection cabinet.

904.10 – The Customer shall be responsible for the service entrance to the source of power as determined by OPU. This includes the removal and replacement of sidewalks and/or pavement as necessary to provide complete service entrance continuity.

904.11 – Where a pad mount transformer is the source, service conductors shall be terminated by OPU.

904.12 – Current transformers (CT's) for metering are provided by OPU. The customer must provide a CT cabinet for all services larger than 400 amps. Refer to Section 610 for requirements.

905 SECONDARY CONNECTION CABINETS

Where secondary connection cabinets are necessary, the following apply:

905.1 - Cabinet assemblies will be suited to the installation and meet OPU and National Electric Code (NEC) requirements.

905.2 - Cabinets shall be constructed with provisions for bar-type or donut-type current transformers.

905.3 - Conduits from service equipment to the connection cabinet and from the transformer to connection cabinet will be furnished and installed by electrical contractor as concrete pads are being formed and poured. Conduit systems shall meet OPU requirements. Above-grade raceway from the transformer to the connection cabinet is not allowed without special permission from OPU.

906 TRANSFORMER CLEARANCES

Where pad-mounted transformers and equipment in pad-mounted enclosures are installed, the minimum clearances specified in Section 1200, Exhibit 11 must be maintained. Vehicle access shall be maintained to allow for transformer replacement and maintenance. Fences, shrubbery, manholes, junction boxes, and trees may be installed by the customer if the specified clearances are maintained, grade is not altered, and the underground cable is not endangered.

907 WINTER INSTALLATION

Underground cable installation at the Customer's request between November 15 and April 30 will be subject to OPU's approval. OPU cannot guarantee installation and connection of service during the winter season.

907.1 – Installations scheduled on or after November 15 will be attempted at the discretion of OPU, based on ground conditions.

907.2 – Where conditions do not permit the completion of a scheduled installation, or where a development cannot be completely brought to grade in time, partial installation will be made under the following conditions:

- (1) Partial installation must conform to final design layout, including placement of one (minimum) permanent transformer or sectionalizing cabinet.
- (2) Partial installations must be contiguous with existing facilities.
- (3) Total project fees must be paid before partial installation will be approved.
- (4) All standard pre-and post-installation site conditions must be met for partial installation.

907.3 – Temporary service to a permanent structure in an undeveloped area will be provided on at "at cost" basis.

908 TOTAL UNDERGROUNDING

OPU does not install underground vaults, manholes, or submersible transformers on Customer property. If the presence of permanent structures up to the property lines, or other conditions, precludes the installation of pad-mounted equipment on the Customer's property, primary service will normally be provided.

909 SERVICE RELOCATION

909.1 – When OPU’s pole or service pedestal must be replaced or relocated because of a request from the Customer, the Customer is responsible for moving or replacing the underground service at his own expense.

909.2 – If OPU replaces or relocates the pole or service pedestal of its own volition, OPU is responsible for the expense of moving or replacing the underground service.

909.3 – OPU shall perform, at its own expense, the labor necessary to attach, maintain, or relocate that portion of the underground service, which is above ground and attached to OPU’s pole or located in vaults, manholes, service pedestals, or junction boxes owned by OPU.

DRAFT

SECTION 1000

UNDERGROUND LOCATIONS

1001 ONE-CALL

Minnesota Statute, Chapter 216D requires an excavator to contact the utility notification center (Gopher State One Call) at least 48 hours before beginning an excavation. The excavation notice may be made by call the center at 1-800-252-1166 and providing the following information:

1. Name of the individual calling.
2. Precise location of the proposed excavation.
3. Name, address and telephone number of the excavator.
4. Excavator's field telephone number.
5. Type and extent of proposed excavation.
6. Any anticipated use of explosives.
7. Date and time when excavation is to commence.

1002 EXCAVATION

"Excavation" means an activity that moves, removes, or otherwise disturbs the soil by use of a motor, engine, hydraulic or pneumatically powered tool, or machine-powered equipment of any kinds, or by explosives. Excavation does not include:

1. The extraction of minerals.
2. The opening of a grave in a cemetery.
3. Normal maintenance of roads and streets if the maintenance does not change the original grade and does not involve the road ditch
4. Plowing, cultivating, harvesting, and similar operations in connection with growing crops, trees, and shrubs, unless any of these activities disturbs the soil to a depth of 18 inches or more.
5. Gardening, unless it disturbs the soil to a depth of 12 inches or more.
6. Planting of windbreaks, shelterbelts, and tree plantations, unless any of these activities disturbs the soil to a depth of 18 inches or more.

1003 REQUESTS

OPU encourages that underground facilities locations be requested prior to all construction or activity that disturbs the soil, including especially those activities that involve hand tools.

1004 CONTACT WITH ELECTRIC CABLE

Any contact with an electric cable during excavation must be reported immediately, day or night, by calling OPU direct at (507) 451-1616.

1005 DAMAGES

The Contractor shall be responsible for any damages to the property of the Utilities resulting from not following the guidelines of Gopher State One-Call. A violation of these regulations shall constitute a misdemeanor.

DRAFT

SECTION 1100

TRANSFORMERS AND TRANSFORMER DATA

1101 TRANSFORMERS

1101.1 – Necessary transformers will be installed and maintained by OPU in accordance with its established Rate Schedules and Electric Service Rules and Regulations.

1101.2 – OPU will not furnish transformers unless they are of standard size and voltage as established by OPU. The Customer shall notify OPU in advance of any change in the Customer's load requirements that may affect the installed transformer capacity.

1102 GROUNDING

1102.1 – All service systems that operate below 600 volts contain a grounded neutral or a grounded phase conductor used as a circuit conductor in the system. The grounded neutral or grounded phase conductor is grounded at the supply transformer and will be run from the transformer bank to the meter socket and to each service disconnection means in accordance with National Electric Code (NEC) Article 250.24(B), or as may be amended.

1103 SPECIAL RULES

1103.1 – When a Customer is furnished primary service by OPU and owns their transformers or other equipment, in accordance with the applicable OPU rate schedule and Electric Service Rules & Regulations, OPU accepts no responsibility for maintaining or replacing the Customer's transformers or other equipment if damaged or destroyed.

1103.2 – The Customer shall provide a minimum of ten (10) feet of level clearance on the door side(s) of pad-mounted transformers and sectionalizing cabinets for hot-stick operation.

1104 FAULT CURRENT

1104.1 – It is OPU's intent to address the Customer's need for information concerning fault current and transformer protective device requirements pertaining to new construction, rewiring, or additional load. Refer to the current edition of the National Electric Code (NEC), Article 110.9 Interrupting Rating and Article 110.16 Arc Flash Hazard Warning, or as may be amended.

1104.2 – Tables located in Section 1200, Exhibit 13 of this book show the maximum available RMS symmetrical fault current that may be expected at the secondary terminals of OPU's distribution transformers. Each fault current value listed in the tables is based on the percent impedance value of the transformer that might be set initially or as a

replacement. No primary source or secondary line impedance has been included since it is generally relatively small, may change, and cannot be accurately forecasted.

Note 1: Because an overloaded transformer is typically replaced with the next larger standard size transformer, and an under-loaded transformer may be replaced with the next smaller standard size transformer, the Customer is encouraged to use this range of transformers to perform their analysis and select equipment such as fuse or circuit breakers and service entrance bus bar bracing. When selecting the fault current interrupting rating of the Customer protection devices, the Customer should also take into account the minimum size transformer that would be required to serve the load rating of the Customer main protection device.

1104.3 – Due to the variability of the transformer and electric distribution system characteristics, these tables should be used as a general guideline and shall not be used as a design tool to replace engineering that may be required by the Code Authorities having jurisdiction. Customers or contractors requiring specific fault current calculations should consult a registered professional engineer of their choice.

Note 1: All installations served from a single-phase pad-mount transformer should as a minimum use the calculations based on the installation of a 37.5 kVA transformer.

Note 2: All temporary construction meter installations may use the actual transformer size.

1104.4 – As a safety measure, OPU recommends that when Customers are performing maintenance work on or near exposed electrical equipment that their electrical system be de-energized whenever possible.

SECTION 1200

EXHIBITS

<u>EXHIBIT</u>		<u>PAGE</u>
1	Typical Underground Residential Metering Arrangement	54
2	Typical Solar Array Residential Metering Arrangement	55
3	Typical Mobile Home Metering Arrangement	56
4	Typical Multiple Metering Arrangement	57
5	Types of Meter Sockets	58
6	Secondary Service Drop Clearances	59
7	Typical Residential Overhead Service Installation	60
8	Typical Residential Service Mast	61
9	OPU & Customer Responsibilities Associated with Underground Single Family Residential Distribution (URD) Installations	62
10	OPU & Customer Responsibilities Associated with Non-Single Family Underground Installations	64
11	Location of Pad-Mounted Transformers near Buildings	66
12	Three-Phase Transformer Concrete Pad Drawings	68
	12-1.....750 kVA & smaller (no Pad-mount CT Cabinet)	69
	12-2.....1000 kVA & larger (no Pad-mount CT Cabinet)	70
	12-3.....750 kVA & smaller (Pad-mount CT Cabinet)	71
	12-4.....1000 kVA & larger (Pad-mount CT Cabinet)	72
13	Transformer Maximum Fault Currents	73
14	Multipliers to Determine Required Capacitor kVARS for Correcting Power Factor	76
15	Customer Planned Electric Outage Request Form	78

EXHIBIT 2 TYPICAL SOLAR ARRAY RESIDENTIAL METERING

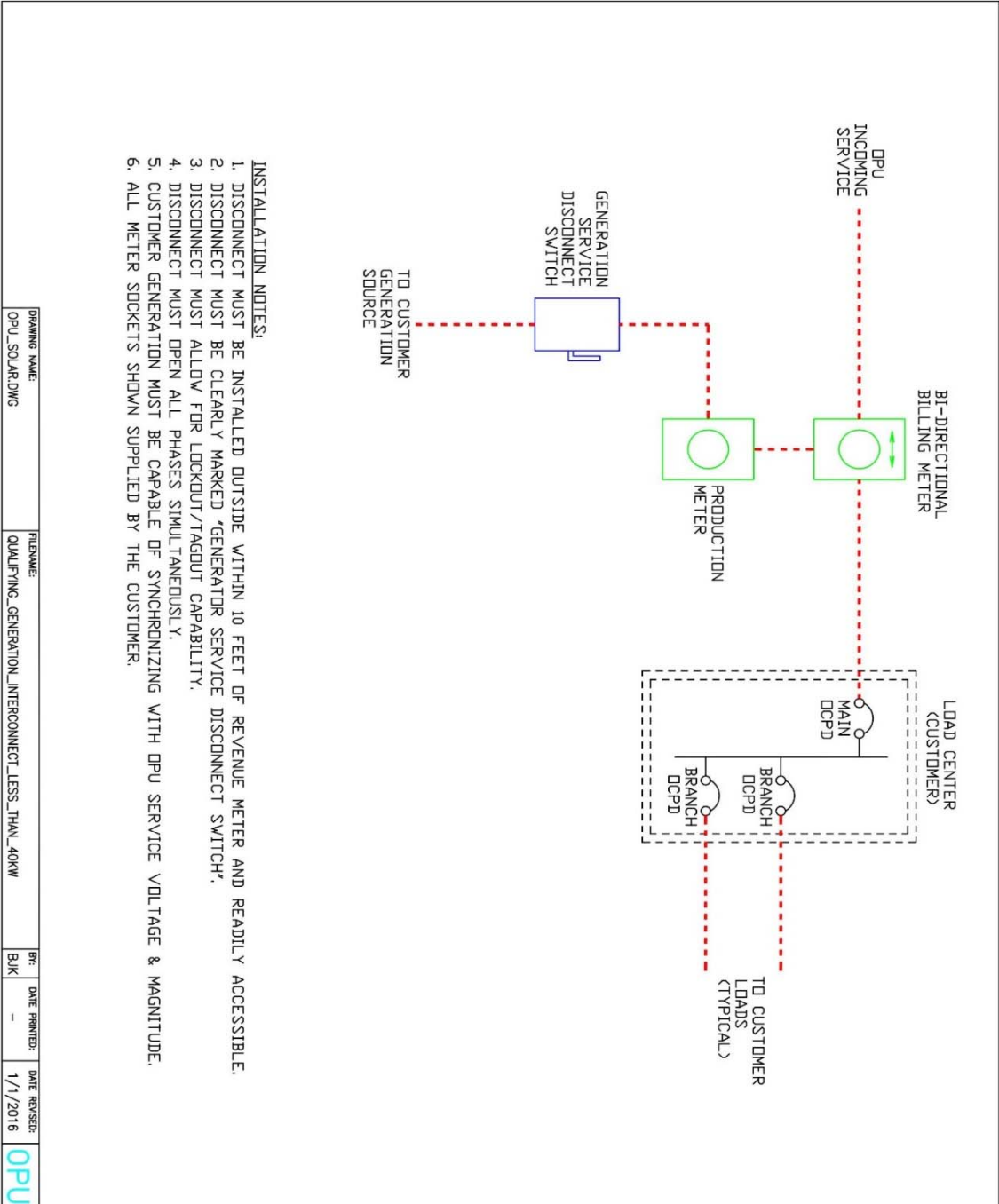

TYPICAL MOBILE HOME METERING
EXHIBIT 3

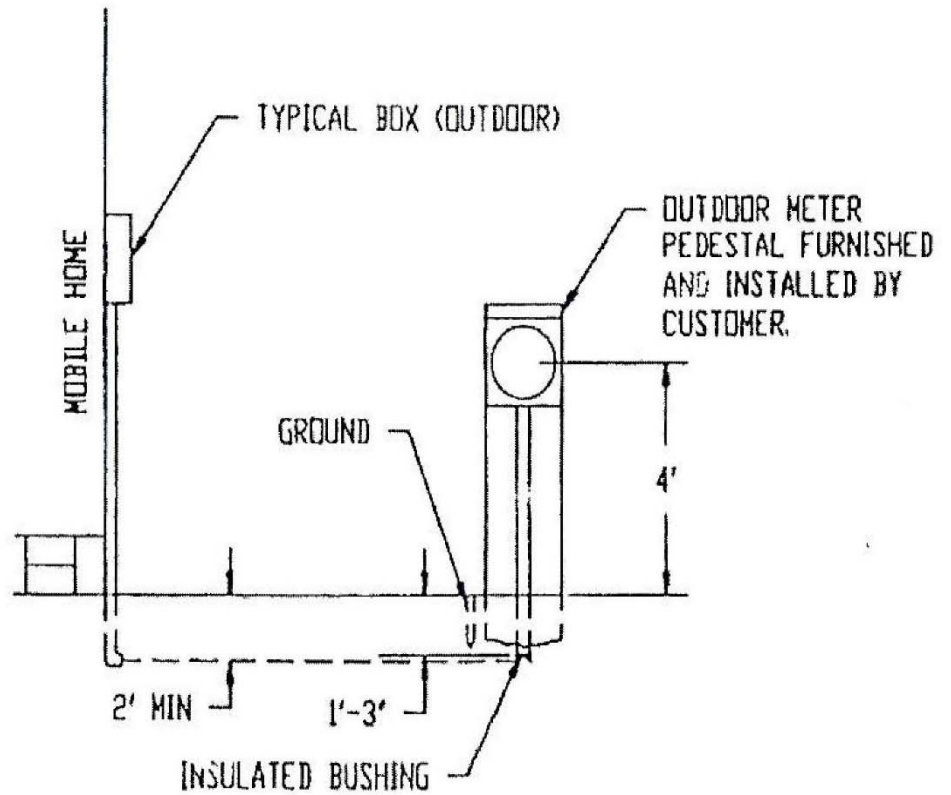

1. METERS ARE TO BE PERMANENTLY LABELED.
2. METERS ARE TO FACE TOWARDS STREET.
3. SERVICE LATERAL FROM THE SECONDARY JUNCTION AT THE PROPERTY LINE, TO THE METER PEDESTAL, TO THE MOBILE HOME, IS THE RESPONSIBILITY OF THE CUSTOMER.

TYPICAL MULTIPLE METERING ARRANGEMENT

EXHIBIT 4

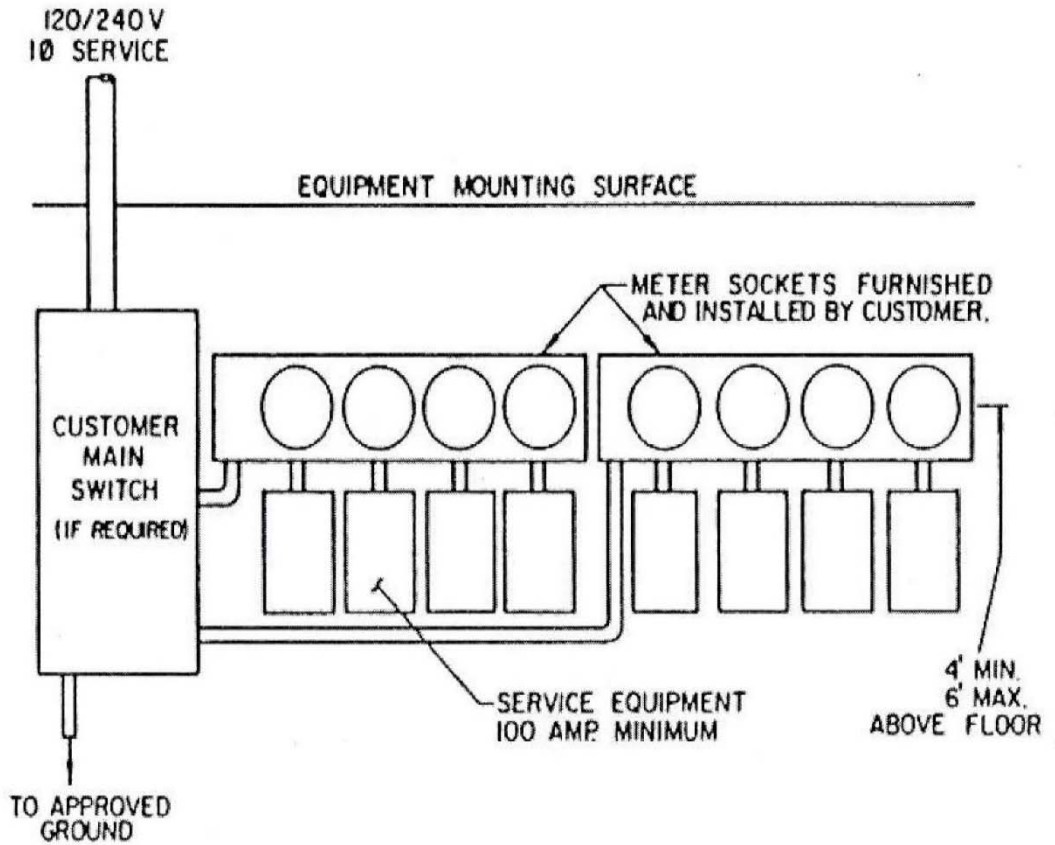

1. METERS ARE TO BE PERMANENTLY LABELED
2. METERS MUST HAVE INDIVIDUAL LOCK-OFF CAPABILITY.
3. METERS MUST BE ACCESSIBLE TO OPU AND TO CUSTOMERS

EXHIBIT 5

TYPES OF METER SOCKETS

SELF CONTAINED

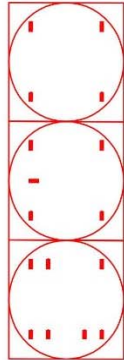

4 TERMINAL
120-240 VOLT
SINGLE PHASE

5 TERMINAL
120-208 VOLT
SINGLE PHASE
FIFTH TERMINAL NEEDS TO BE LOCATED IN THE 9 O'CLOCK POSITION

7 TERMINAL
120-208, 277-480 VOLT
THREE PHASE, 4-WIRE

SELF-CONTAINED NOTES:

1. ALL SELF-CONTAINED METER SOCKETS MUST CONTAIN A LEVER BYPASS AND WILL NEED TO BE PURCHASED BY THE CUSTOMER OR ELECTRICIAN.
2. THE MAXIMUM AMPERAGE FOR A SELF CONTAINED METER SHALL BE 320A.

INSTRUMENT RATED

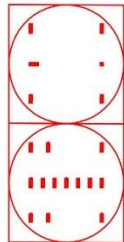

6 TERMINAL
120-240 VOLT
SINGLE PHASE

13 TERMINAL
120-208, 240, 277-480 VOLT
THREE PHASE

INSTRUMENT RATED NOTES:

1. ALL INSTRUMENT-RATED METER SOCKETS MUST BE PURCHASED FROM OPU'S METERING DEPARTMENT.

FILENAME
METER-TYPES.DWG

PATH
-

BY: DATE PRINTED: DATE REVISED:
BJK - 1/1/2016

OPU

EXHIBIT 6
SECONDARY SERVICE DROP CLEARANCES

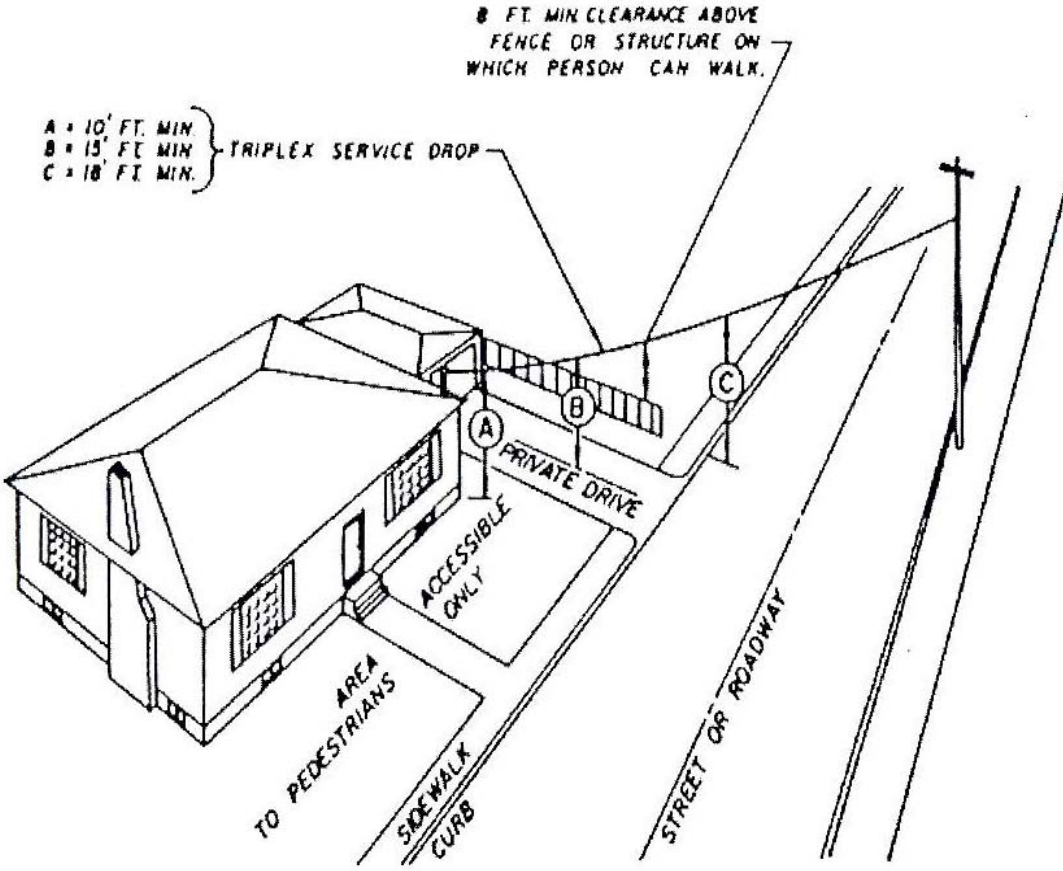

EXHIBIT 7

TYPICAL RESIDENTIAL OVERHEAD SERVICE INSTALLATION

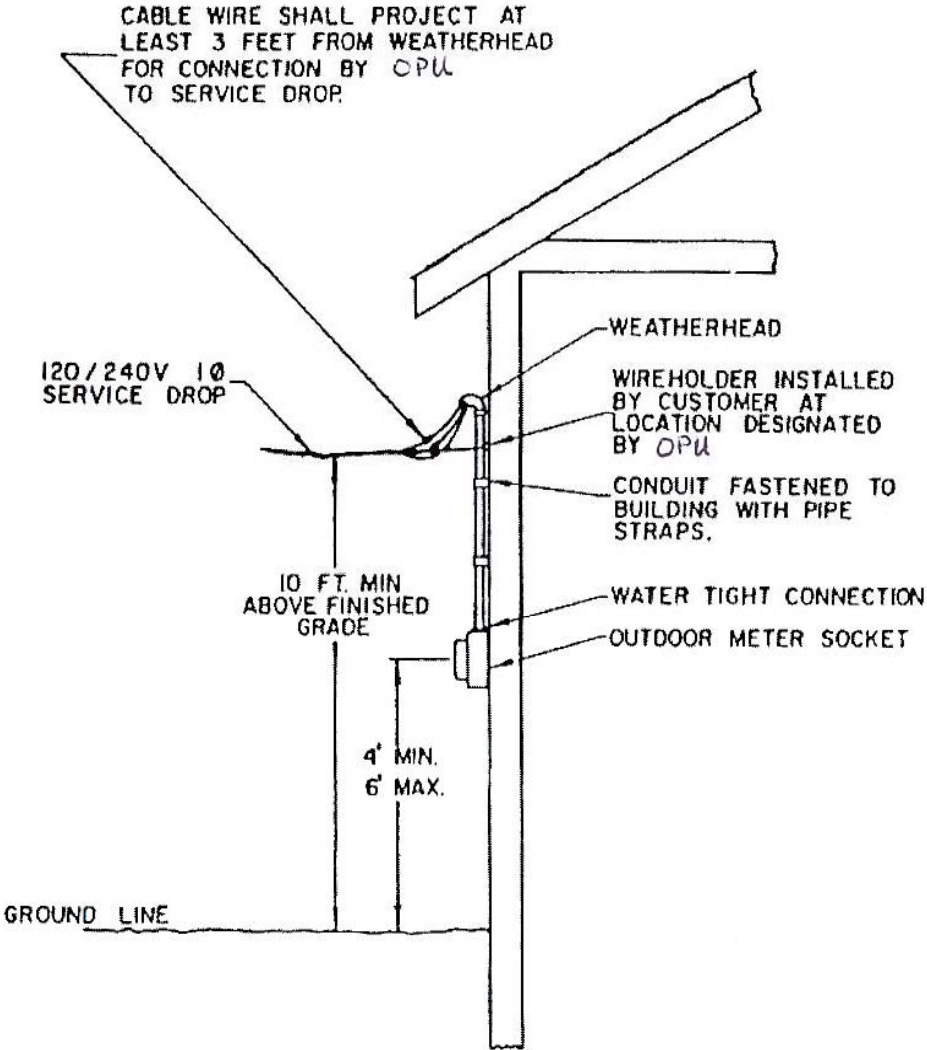

EXHIBIT 8
TYPICAL RESIDENTIAL SERVICE MAST

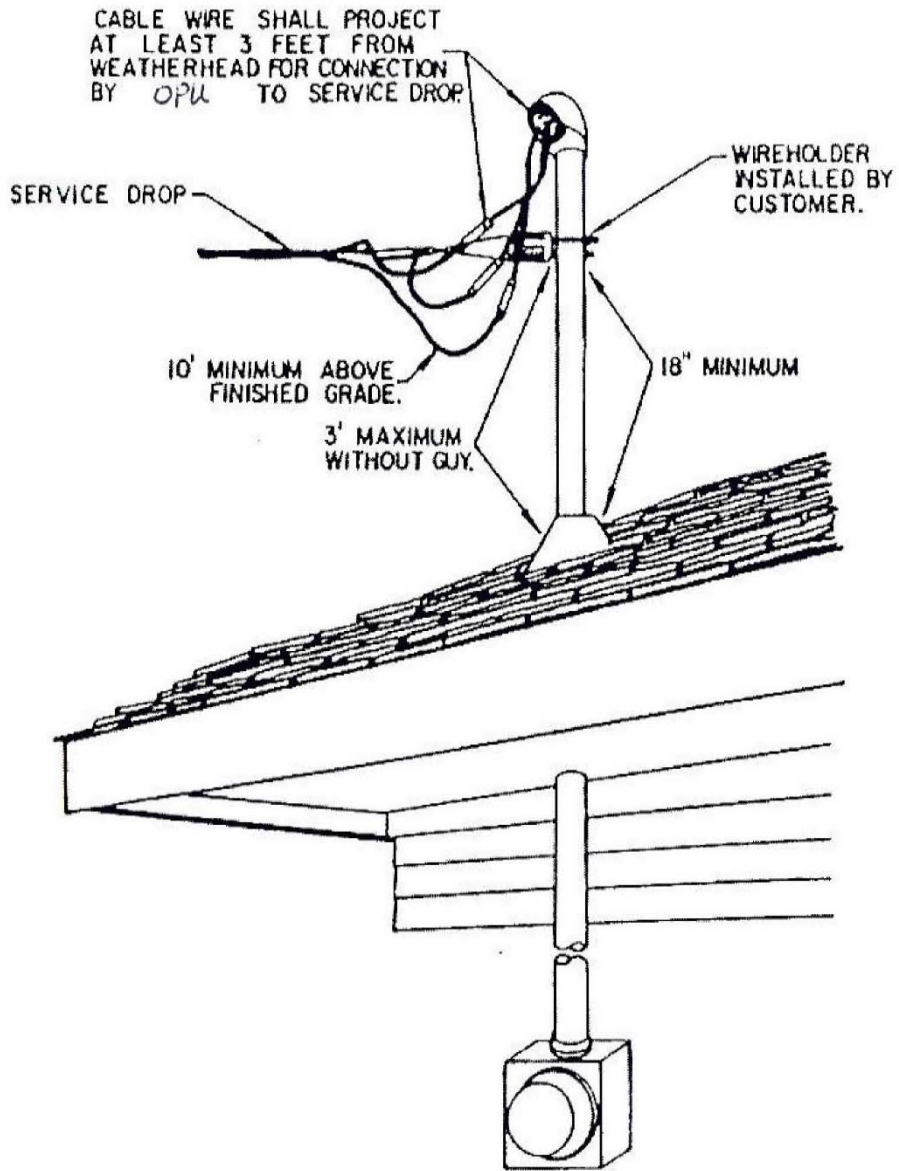

EXHIBIT 9

OPU AND CUSTOMER RESPONSIBILITIES ASSOCIATED WITH UNDERGROUND SINGLE FAMILY RESIDENTIAL DISTRIBUTION (URD) INSTALLATIONS

OPU Responsibilities:

1. Designate point of delivery or transformer location.
2. Supply and install all primary cable, transformer pads, and pad-mounted transformers.
3. Make all primary terminations and connections and install the grounding system.
4. Supply and install secondary connection pedestals and secondary cable to the pedestals (if required).
5. Install and terminate OPU's service cable from point of delivery (pole, service pedestal, or pad-mount transformer) location to the line side of the Customer's meter socket.
6. Supply and install the meter set, including the meter(s) and any other meter accessories needed for billing purposes, excluding the meter socket.
7. Energize the service only when authorized to do so by an authorized State of Minnesota electrical inspector.
8. Supply all conduit on terminal poles, excluding the first 10' section.

Customer Responsibilities:

1. Contacting OPU to obtain the location and routing of OPU's facilities, filling out an "Application for Service" and payment of all applicable OPU fees prior to the commencement of work.
2. Providing necessary easements and clearing area of all construction obstructions located along OPU's proposed facilities route.
3. Bringing area to final grade before installation of service cable and transformers. Install grade stakes at all front lot line property corners. Grade changes requiring cable adjustments may result in charges to the party requiring the changes.
4. Providing trench from point of interconnection with OPU (pole, service pedestal, or pad-mount transformer) to Customer's meter socket location.
5. Backfilling and compaction of trench after installation of service cable.
6. Supplying and installing an OPU approved meter socket on an outside wall. Customer shall install a minimum 2-inch Schedule 80 PVC conduit for the service cable entry into the meter socket. Service conduit shall extend a minimum of 16 inches below final grade and have insulated bushings.
7. Allowing OPU to install cable/conduit prior to installation of sidewalks, curbing, asphalt, topsoil, sprinklers, etc. along the proposed cable route.
8. Protecting OPU facilities from damage during construction period.
9. Having all required inspections of installation performed and approved by an authorized State of Minnesota electrical inspector.

10. Notifying OPU prior to any proposed building or grade changes within 10 feet of the electrical service or installed cable route.
11. Contacting OPU a minimum of 1 business day in advance of when a service is to be installed so that OPU can schedule a service truck to meet the Customer/contractor on-site to perform the work.

DRAFT

EXHIBIT 10

OPU AND CUSTOMER RESPONSIBILITIES ASSOCIATED WITH NON-SINGLE FAMILY UNDERGROUND INSTALLATIONS

OPU Responsibilities:

1. Designate service location or transformer location.
2. Supply and install pad-mounted transformer.
3. Supply and install all primary cable to the Customer after said Customer furnishes and installs conduit for the entire distance from the property line to the transformer.
4. Make all primary terminations and connections at the transformer.
5. Connect Customer's secondary cables to OPU's transformer secondary terminals after Customer's wiring has been inspected and approved by an authorized State of Minnesota electrical inspector.
6. Supply and install one (1) meter set for each Customer, including all meters required for billing purposes and any accessories such as totalizers, current and potential transformers, phase-shifting transformers, test switches, and color code meter wiring.
7. Energize the service only when authorized to do so by the authorized State of Minnesota electrical inspector.
8. Inspect Customer-furnished equipment required by OPU. Installations not in compliance with OPU regulations will be rejected.

Customer Responsibilities:

1. Contacting OPU to obtain the location and routing of OPU's facilities, fill out an "Application for Service" in-person at the OPU Power Plant office, and pay all applicable OPU fees prior to the commencement of work.
2. Providing necessary easements and clearing area of all construction obstructions located along OPU's proposed facilities route.
3. Bringing area to final grade before installation of cable and transformers. Grade changes requiring cable adjustments may result in charges to the party requiring the changes.
4. Furnishing and installing electrical conduit per OPU's specifications with marking tape to the point of interconnection with OPU. All conduit shall be installed a minimum of 36" below final grade. All conduit radiuses less than 60" shall be factory fabricated. Minimum elbow (bend) radius shall be 36". Furnish and install pull rope in conduit. **Final location of the riser sweep attachment to the pole must be approved by OPU personnel.**
5. Backfilling and compaction of primary conduit trench after installation of conduit by contractor. OPU must perform an approval inspection of the conduit and GPS the installation prior to backfilling and compaction of the trench.

6. Furnishing and installing a concrete transformer pad and ground rod or loop to OPU specifications. Standard transformer pad details are found under Exhibit 12. Contact OPU Engineering to obtain the correct transformer pad size for the specific service being installed. Notify OPU Engineering to inspect formed pad and ground rod or loop prior to pouring concrete.
7. Providing a location for the transformer that meets the clearance requirements outlined in Exhibit 11.
8. Installing protective bollards if transformer is to be installed in a parking area or area subject to vehicular traffic.
9. Furnishing and installing all secondary cables, cabinets, and conduits from the transformer to the Customer's service entrance.
10. Allowing OPU to install cable/conduit prior to installation of sidewalks, curbing, asphalt, topsoil, sprinklers, etc. along the cable route.
11. Protecting OPU facilities from damage during construction period.
12. Having all required inspections of facility performed and approved by an authorized State of Minnesota electrical inspector.
13. Providing easy accessibility to transformer location 24 hours a day.
14. Notifying OPU prior to any proposed building or grade changes within 10 feet of the electrical service or installed cable route.
15. Notifying OPU as far in advance as possible when any unusual loads are anticipated, such as special medical equipment, arc welders, elevators, or any other load or equipment that could affect OPU's system or any other Customer.
16. Contacting OPU a minimum of 1 business day in advance of when a service is to be installed so that OPU can schedule a service truck to meet the Customer/contractor on-site to perform the work.

EXHIBIT 11

LOCATION OF PAD-MOUNTED TRANSFORMERS NEAR BUILDINGS

I. NON-COMBUSTIBLE WALLS

(Included in this class would be wood framed brick veneered buildings, metal clad steel framed buildings, asbestos-cement-board walled metal framed buildings and masonry buildings)

Pad-mounted oil insulated transformers may be located a minimum distance of 36" from non-combustible walls if all of the following clearances are maintained:

- a) Doors
Pad-mounted oil insulated transformers shall not be located within a zone extending 20-ft. outward and 10-ft. to either side of a building door.
- b) Air Intake Openings
Pad-mounted oil insulated transformers shall not be located within a zone extending 10-ft. outward and 10-ft. to either side of an air intake opening located at the level of the transformer (level of the transformer is to be interpreted as within 10-ft. of finished grade). If the air intake opening is located above the transformer level, the distance from the transformer to the opening shall be a minimum of 25-ft.
- c) Windows or Openings other than Air Intake
 - (1) Pad-mounted oil insulated transformers shall not be located within a zone extending 10-ft. outward and 3-ft. to either side of a building window or opening other than an air intake for the first story of the building.
 - (2) Pad-mounted oil insulated transformers shall not be located less than 5-ft. from any part of a second story window or opening other than an air intake.
- d) Combustible First Story Overhang
If a combustible first story overhang exists, a 10-ft. distance from the edge of the transformer to the edge of the overhang (combination of vertical and horizontal distance) shall be required in addition to the other clearances described under parts (a) through (c) above.

II. COMBUSTIBLE WALLS

(Included in this class would be wood buildings and metal clad buildings with wood frame construction)

Pad-mounted oil insulated transformers shall be located at a minimum of 10-ft. from the building wall. If a combustible first floor overhang exists, a 10-ft. distance from the edge of the transformer to the edge of the overhang (combination of vertical and horizontal distance) shall be required in addition to the 10-ft. clearance specified above.

III. BARRIERS

(Included in this class are reinforced concrete, brick or concrete block barrier walls)

If the clearances specified under Section I or II cannot be obtained, a fire resistant barrier shall be constructed in lieu of the clearances. The barrier, when required, is provided by the Customer. The following methods of construction are acceptable:

a) Non-Combustible Walls

The barrier shall extend to a projection line from the corner of the pad-mount transformer to the furthest corner of the window, door or opening in question. The height of the barrier shall extend at least 1-ft. above the top of the pad-mount transformer.

b) Combustible Walls

The barrier shall extend 3-ft. beyond each side of the pad-mount transformer. The height of the barrier shall extend at least 3-ft. above the top of the pad-mount transformer. If a combustible first floor overhang exists, the required 3-ft. clearance specified shall be measured from the edge of the overhang rather than from the building wall.

IV. FIRE ESCAPES

Pad-mounted oil insulated transformers shall be located such that a minimum clearance of 20-ft is maintained from fire escapes at all times.

Exception: Pad-mounted transformers may be located closer to a fire escape than the 20-ft. minimum when a fire resistant barrier is constructed around the transformer (side walls and roof). The barrier shall extend a minimum of 1-ft beyond the transformer. The transformer and barrier shall not in any way obstruct the fire escape exit. A 10-ft. clearance is required in front of the pad-mounted transformer doors. Adequate transformer accessibility and ventilation must be provided.

V. DECORATIVE COMBUSTIBLE ENCLOSURE

Decorative combustible enclosures (fence) installed by the Customer around pad-mounted transformers adjacent to a combustible building wall shall not extend more than 24-in. beyond the transformer towards the combustible wall. A 10-ft. clearance is required in front of the pad-mounted transformer doors. Adequate transformer accessibility and ventilation must be provided.

EXHIBIT 12

THREE PHASE TRANSFORMER CONCRETE PADS

(DRAWINGS ARE SHOWN ON THE FOLLOWING PAGES)

DRAFT

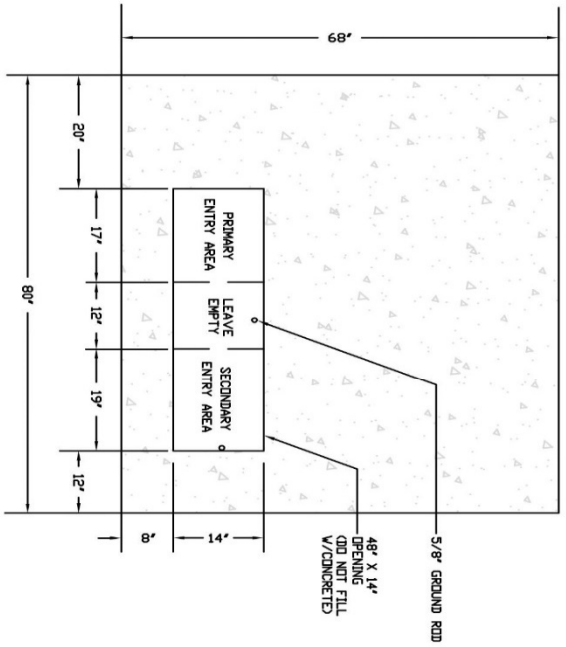

TOP VIEW

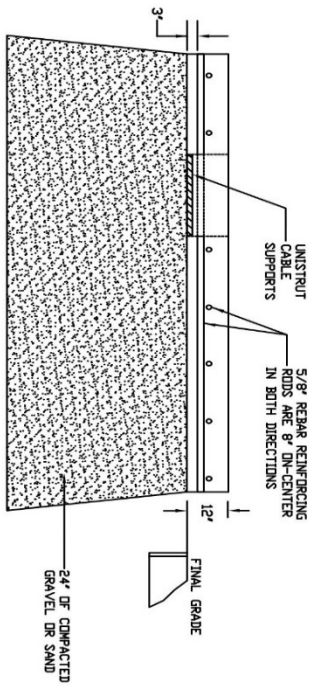

CROSS-SECTION SIDE VIEW

FORM MUST BE APPROVED BY DPU BEFORE CONCRETE IS POURED

NOTES:
 A. PAD TO BE POURED IN PLACE WITH CONCRETE TESTING NO LESS THAN 3000 PSI (6 BAG MIX). THE GROUND UNDER THE PAD SHALL BE LEVEL, AT FINAL GRADE, FREE OF STANDING WATER AND FIRM TO AVOID SETTLING. NO FROZEN BACKFILL IS TO BE USED. THE MINIMUM COMPACTION OF THE SOIL IS TO BE 90%. THE CONCRETE MUST BE AN AIR-ENTRAINED MIX DESIGN.

B. MINIMUM CLEARANCE'S AROUND PAD SHALL BE:
 BACK = 36'
 SIDES = 36'
 FRONT = 120' (FOR HOT STICK MAINTENANCE)
 PAD LOCATIONS MUST ALSO MEET NATIONAL ELECTRICAL CODE, ARTICLE 450-27 AND NATIONAL ELECTRIC SAFETY CODE SECTION 15, ARTICLE 152-A2.
 THE PAD MUST HAVE A 1/2 MIN.-5% MAX. GRADE AWAY FROM THE PAD FOR THE MINIMUM CLEARANCE DISTANCES + 2 FEET.

THE TRANSFORMER DOORS MUST FACE AWAY FROM STRUCTURES.

C. TRANSFORMERS LOCATED IN AREAS EXPOSED TO VEHICULAR TRAFFIC SHALL BE PROTECTED WITH SUITABLE PIPE OR 1" BEAMS ON ALL EXPOSED SIDES SUPPLIED & INSTALLED BY THE CUSTOMER.

D. FORMS MUST BE APPROVED BY DPU PRIOR TO CONCRETE PLACEMENT. ALL EXPOSED EDGES OF CONCRETE MUST BE RADIUS TOoled.

E. TRANSFORMER PAD LOCATIONS MUST BE APPROVED BY DPU PRIOR TO PLACEMENT. LOCATION MUST BE READILY ACCESSIBLE BY DPU DURING AND AFTER PLACEMENT. IF THE PAD IS PLACED AWAY FROM A SOLID DRIVING SURFACE THE OWNER SHALL BE RESPONSIBLE FOR PROVIDING ACCESS AND ANY RESTORATION REQUIRED FROM DPU ACCESSING THIS LOCATION FOR ANY WORK REQUIRED DURING AND AFTER PLACEMENT. THE OWNER SHALL MAINTAIN A FREE AND UNENCUMBERED PATHWAY TO THE TRANSFORMER.

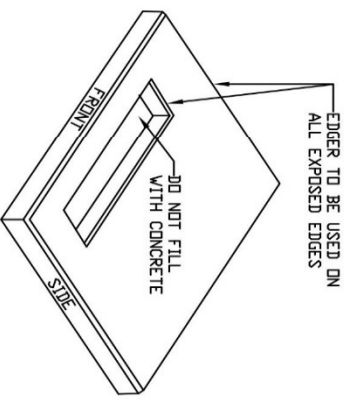

FORM MUST BE APPROVED BY DPU PRIOR TO CONCRETE BEING POURED

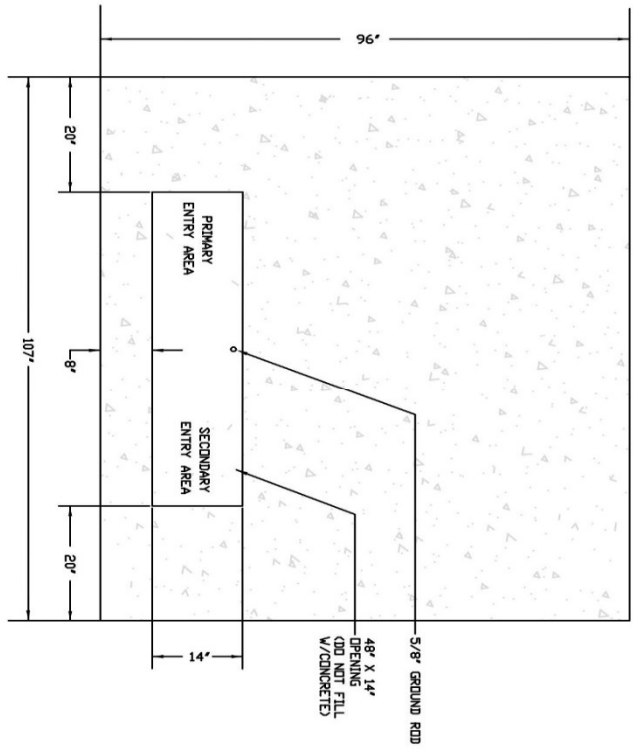

TOP VIEW

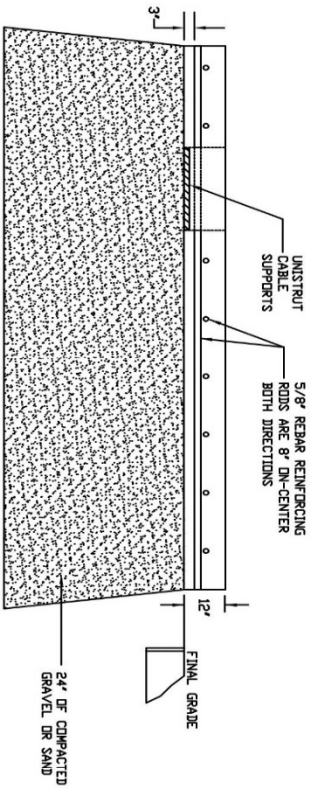

CROSS-SECTION SIDE VIEW

**FORM MUST BE APPROVED
BY DPU BEFORE
CONCRETE IS POURED**

NOTES:

- A. PAD TO BE POURED IN PLACE WITH CONCRETE TESTING NO LESS THAN 3000 P.S.I. (6 BAG MIX). THE GROUND UNDER THE PAD SHALL BE LEVEL, AT FINAL GRADE, FREE OF STANDING WATER AND FIRM TO AVOID SETTLING. NO FROZEN BACKFILL IS TO BE USED. THE MINIMUM COMPACTION OF THE SOIL IS TO BE 90%. THE CONCRETE MUST BE AN AIR-ENTRAINED MIX DESIGN.
- B. MINIMUM CLEARANCES AROUND PAD SHALL BE:
 BACK = 36"
 SIDES = 36"
 FRONT = 120" (FOR HOT STICK MAINTENANCE)
- C. PAD LOCATIONS MUST ALSO MEET NATIONAL ELECTRICAL CODE, ARTICLE 450-27 AND NATIONAL ELECTRIC SAFETY CODE SECTION 15, ARTICLE 152-A2. THE PAD MUST HAVE A 1% MIN.-5% MAX. GRADE AWAY FROM THE PAD FOR THE MINIMUM CLEARANCE DISTANCES + 2 FEET.
 THE TRANSFORMER DOORS MUST FACE AWAY FROM STRUCTURES.
- D. TRANSFORMERS LOCATED IN AREAS EXPOSED TO VEHICULAR TRAFFIC SHALL BE PROTECTED WITH SUITABLE PIPE OR 1" BEAMS ON ALL EXPOSED SIDES SUPPLIED & INSTALLED BY THE CUSTOMER.
- E. FORMS MUST BE APPROVED BY DPU PRIOR TO CONCRETE PLACEMENT. ALL EXPOSED EDGES OF CONCRETE MUST BE RADIUS TOELED.
- F. TRANSFORMER PAD LOCATIONS MUST BE APPROVED BY DPU PRIOR TO PLACEMENT. LOCATION MUST BE READILY ACCESSIBLE BY DPU DURING AND AFTER PLACEMENT. IF THE PAD IS PLACED AWAY FROM A SOLID DRIVING SURFACE THE DOWNER SHALL BE RESPONSIBLE FOR PROVIDING ACCESS AND ANY RESTORATION REQUIRED FROM DPU ACCESSING THIS LOCATION FOR ANY WORK REQUIRED DURING AND AFTER PLACEMENT. THE OWNER SHALL MAINTAIN A FREE AND UNENCUMBERED PATHWAY TO THE TRANSFORMER.

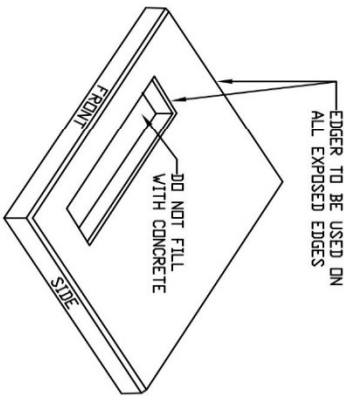

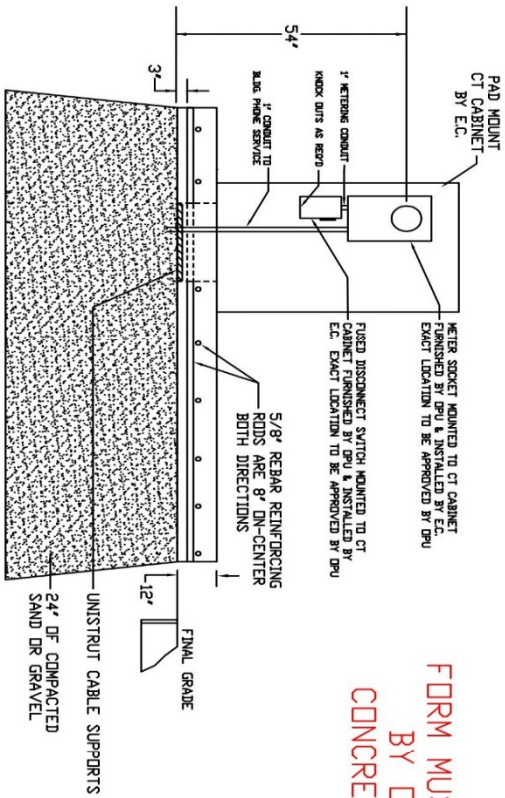
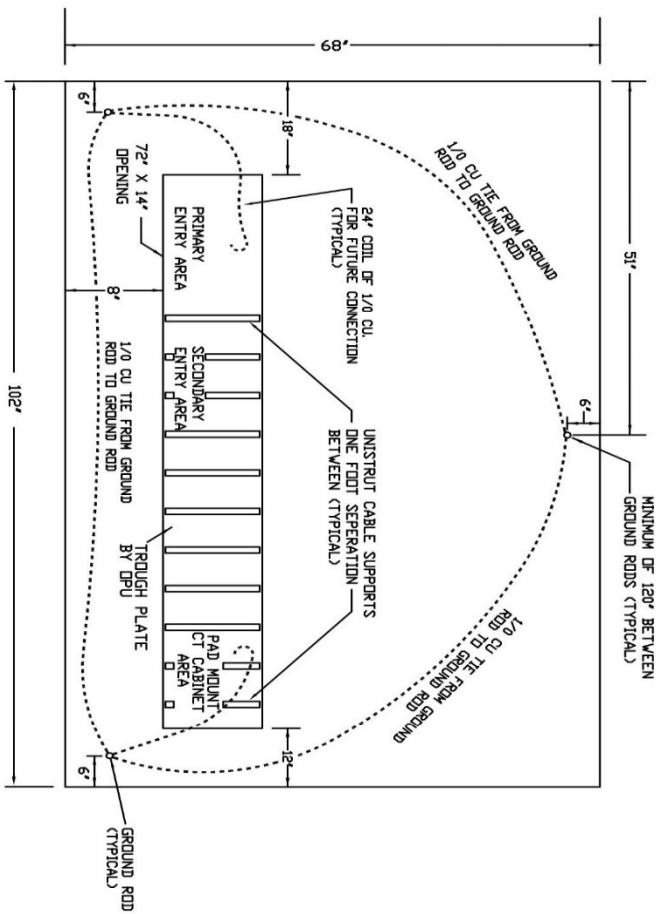

**FORM MUST BE APPROVED
BY DPU BEFORE
CONCRETE IS POURED**

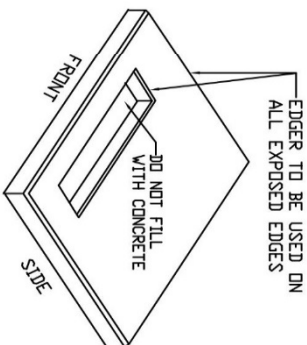

NOTES

- A. PAD TO BE POURED IN PLACE WITH CONCRETE TESTING NO LESS THAN 3000 P.S.I. (6 BAG MIX). THE GROUND UNDER THE PAD SHALL BE LEVEL, AT FINAL GRADE, FREE OF STANDING WATER AND FIRM TO AVOID SETTLING. NO FROZEN BACKFILL IS TO BE USED. THE MINIMUM COMPACTION OF THE SOIL IS TO BE 90%. THE CONCRETE MUST BE AN AIR-ENTRAINED MIX DESIGN.
- B. MINIMUM CLEARANCE'S AROUND PAD
FRONT = 120' FOR HOT STICK MAINTENANCE
BACK = 36'
SIDES = 36'
- C. TRANSFORMERS LOCATED IN AREAS EXPOSED TO VEHICULAR TRAFFIC SHALL BE PROTECTED WITH SUITABLE PIPE OR 7" BEAMS ON ALL EXPOSED SIDES SUPPLIED & INSTALLED BY THE CUSTOMER.
- D. CUSTOMER TO FURNISH ALL CONDUIT WITH PULL WIRE INCLUDED IN EACH CONDUIT TO BE ELECTRICAL GRADE CONDUIT, MINIMUM SCH. 40 P.V.C. OR RIGID GALVANIZED STEEL ONLY, IF REQ'D BY DPU.
- E. STAKES MUST BE APPROVED BY DPU PRIOR TO CONCRETE PLACEMENT. METER STRIPS AND 1" METER CONDUIT MUST BE IN PLACE PRIOR TO PLACING THE CONCRETE. ALL EXPOSED EDGES OF CONCRETE MUST BE RADIUS TOoled.
- F. TRANSFORMER PAD LOCATIONS MUST BE APPROVED BY DPU PRIOR TO PLACEMENT. LOCATION MUST BE READILY ACCESSIBLE BY DPU DURING AND AFTER PLACEMENT. IF THE PAD IS PLACED AWAY FROM A SLID DRIVING SURFACE THE DAWNER SHALL BE RESPONSIBLE FOR PROVIDING ACCESS AND ANY RESTORATION REQUIRED FROM DPU ACCESSING THIS LOCATION FOR ANY WORK REQUIRED DURING AND AFTER PLACEMENT. THE DAWNER SHALL MAINTAIN A FREE AND UNENCUMBERED PATHWAY TO THE TRANSFORMER.

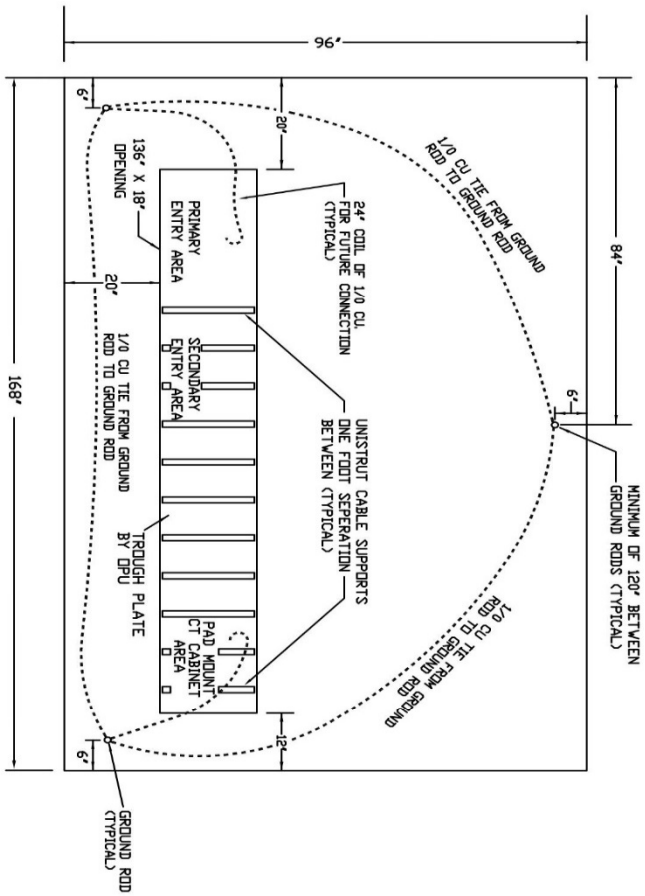

TOP VIEW

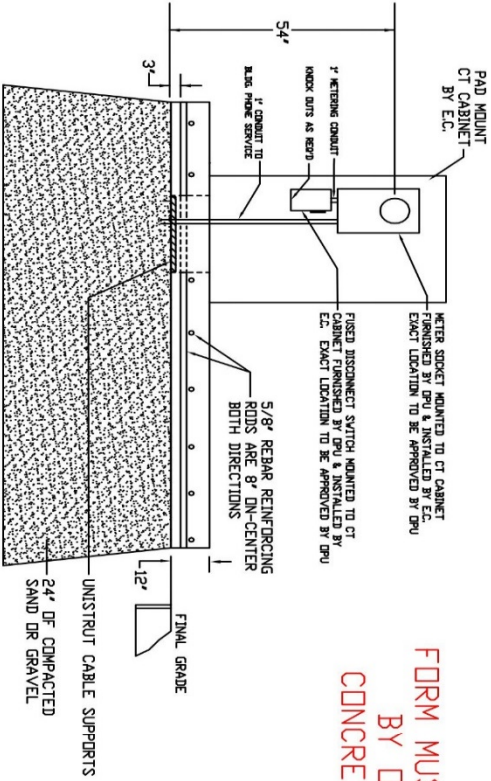

CROSS-SECTION SIDE VIEW

**FORM MUST BE APPROVED
BY DPU BEFORE
CONCRETE IS POURED**

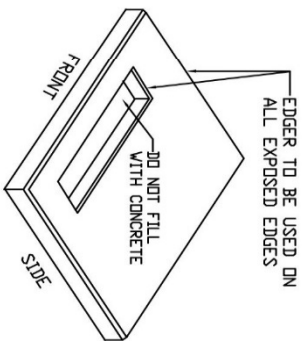

NOTES:

- A. PAD TO BE POURED IN PLACE WITH CONCRETE TESTING NO LESS THAN 3000 P.S.I. (6 BAG MIX). THE GROUND UNDER THE PAD SHALL BE LEVEL, AT FINAL GRADE, FREE OF STANDING WATER AND FIRM TO AVOID SETTLING. NO FROZEN BACKFILL IS TO BE USED. THE MINIMUM COMPACTION OF THE SOIL IS TO BE 90%. THE CONCRETE MUST BE AN AIR-ENTRAINED MIX DESIGN.
- B. MINIMUM CLEARANCES AROUND PAD
BACK = 36"
FRONT = 120' (FOR HOT STICK MAINTENANCE)
- C. PAD LOCATIONS MUST ALSO MEET NATIONAL ELECTRICAL CODE, ARTICLE 450-87 AND NATIONAL ELECTRIC SAFETY CODE SECTION 15, ARTICLE 152-42. THE PAD MUST HAVE A 1/2" MIN-5/8" MAX. GRADE AWAY FROM THE PAD FOR THE MINIMUM CLEARANCE DISTANCES + 2 FEET.
- D. THE TRANSFORMER DOORS MUST FACE AWAY FROM STRUCTURES.
- E. TRANSFORMERS LOCATED IN AREAS EXPOSED TO VEHICULAR TRAFFIC SHALL BE PROTECTED WITH SUITABLE PIPE OR 1" BEAMS ON ALL EXPOSED SIDES SUPPLIED & INSTALLED BY THE CUSTOMER.
- F. CUSTOMER TO FURNISH ALL CONDUIT WITH PULL WIRE INCLUDED IN EACH CONDUIT TO BE ELECTRICAL GRADE CONDUIT, MINIMUM SCH. 40 P.V.C. OR RIGID GALVANIZED STEEL D.I.V., IF REQ'D BY DPU.
- G. FORMS MUST BE APPROVED BY DPU PRIOR TO CONCRETE PLACEMENT. METER STRAPS AND 1" METER CONDUIT MUST BE IN PLACE PRIOR TO PLACING THE CONCRETE. ALL EXPOSED EDGES OF CONCRETE MUST BE RADIUS TOOLED.
- H. TRANSFORMER PAD LOCATIONS MUST BE APPROVED BY DPU PRIOR TO PLACEMENT. LOCATION MUST BE READILY ACCESSIBLE BY DPU DRIVING AND AFTER PLACEMENT. IF THE PAD IS PLACED AWAY FROM A SOLID DRIVING SURFACE THE OWNER SHALL BE RESPONSIBLE FOR PROVIDING ACCESS AND ANY RESTORATION REQUIRED FROM DPU ACCESSING THIS LOCATION FOR ANY WORK REQUIRED DURING AND AFTER PLACEMENT. THE OWNER SHALL MAINTAIN A FREE AND UNOBSTRUCTED PATHWAY TO THE TRANSFORMER.

EXHIBIT 13

TRANSFORMER MAXIMUM FAULT CURRENTS

SINGLE-PHASE PADMOUNT TRANSFORMERS					
EXPECTED SINGLE-PHASE FAULT CURRENTS (IN RMS AMPS) AT THE SECONDARY TERMINALS					
TRANSFORMER KVA	TRANSFORMER % IMPED	FAULT CURRENT 240V SECONDARY	PROTECTIVE DEVICE, FUSE LINK		
			BAY-O-NET 7200V PRIMARY	RATING (A)	
25.0	1.0	10,417	4000358C05	8	
37.5	1.0	15,625	4000358C05	8	
50.0	1.1	18,939	4000358C08	15	
75.0	1.1	28,409	4000358C08	15	
100.0	1.1	37,879	4000358C10	25	
167.0	1.2	57,986	4000358C12	50	

Table 1 – Single Phase Underground Transformers

EXHIBIT 13 – CONTINUED

SINGLE-PHASE OVERHEAD TRANSFORMERS				
EXPECTED SINGLE-PHASE FAULT CURRENTS (IN RMS AMPS) AT THE SECONDARY TERMINALS				
TRANSFORMER KVA	TRANSFORMER % IMPED	FAULT CURRENT 240V SECONDARY	PROTECTIVE DEVICE, OVERHEAD FUSE	
			RATED AMPS 7200V PRIMARY	LINK RATING
5.0	1.2	1,736	0.69	2K
7.5	1.2	2,604	1.04	2K
10.0	1.2	3,472	1.39	2K
15.0	1.2	5,208	2.08	3K
25.0	1.2	8,681	3.47	5K
37.5	1.2	13,021	5.21	6K
50.0	1.3	16,026	6.94	8K
75.0	1.3	24,038	10.42	12K
100.0	1.4	29,762	13.89	15K
167.0	1.7	40,931	23.19	25K

Table 2 – Single Phase Overhead Transformers

EXHIBIT 13 – CONTINUED

THREE-PHASE PADMOUNT TRANSFORMERS				
EXPECTED THREE-PHASE FAULT CURRENTS (IN RMS AMPS) AT THE SECONDARY TERMINALS				
TRANSFORMER KVA	TRANSFORMER % IMPED	FAULT CURRENT 120/208V SECONDARY	FAULT CURRENT 277/480V SECONDARY	TRANSFORMER PROTECTIVE DEVICE BAY-O-NET FUSE LINK
45.0	1.3	9,620	N/A	4000358C05
75.0	1.3	16,033	6,948	4000358C05
112.5	1.4	22,331	9,677	4000358C05
150.0	1.4	29,775	12,903	4000358C08
225.0	1.5	41,685	18,064	4000358C08
300.0	1.5	55,580	24,085	4000358C10
500.0	1.6	86,844	37,632	4000353C12
750.0	4.5	46,317	20,071	4000353C14
1000	5.1	N/A	23,613	4000353C14
1500	5.1	N/A	35,419	4000353C16
2000	5.1	N/A	47,225	4000353C16
2500	5.1	N/A	59,031	4000353C17

Table 3 – Three Phase Pad-mount Transformers

EXHIBIT 14

MULTIPLIERS TO DETERMINE REQUIRED CAPACITOR KVARs FOR CORRECTING POWER FACTOR

Original Power Factor	Corrected Power Factor						
	<u>90%</u>	<u>92%</u>	<u>94%</u>	<u>95%</u>	<u>96%</u>	<u>98%</u>	<u>100%</u>
60%	0.849	0.907	0.097	1.005	1.042	1.130	1.333
62%	0.781	0.839	0.903	0.937	0.974	1.062	1.265
64%	0.716	0.775	0.838	0.872	0.909	0.998	1.201
66%	0.654	0.712	0.775	0.810	0.847	0.935	1.138
68%	0.594	0.652	0.715	0.750	0.787	0.875	1.078
70%	0.536	0.594	0.657	0.692	0.729	0.817	1.020
72%	0.480	0.538	0.601	0.635	0.672	0.761	0.964
74%	0.425	0.483	0.546	0.580	0.617	0.706	0.909
76%	0.371	0.429	0.492	0.526	0.563	0.652	0.855
78%	0.318	0.376	0.439	0.474	0.511	0.599	0.802
80%	0.266	0.324	0.387	0.421	0.458	0.547	0.750
82%	0.214	0.272	0.335	0.369	0.406	0.495	0.698
84%	0.162	0.220	0.283	0.317	0.354	0.443	0.646
86%	0.109	0.167	0.230	0.265	0.302	0.390	0.593
88%	0.055	0.114	0.117	0.211	0.248	0.337	0.540
90%	0.000	0.058	0.121	0.156	0.193	0.281	0.484
92%		0.000	0.063	0.097	0.134	0.223	0.426
94%			0.000	0.034	0.071	0.160	0.363
96%					0.000	0.089	0.292
98%						0.000	0.203
100%							0.000

INSTRUCTIONS:

1. Determine the average power factor that your system operates at during peak demand months. Call this your ORIGINAL POWER FACTOR.
2. In the row titled CORRECTED POWER FACTOR at the top of the page, find the power factor that you wish to correct your system.
3. Read from left to right along the row corresponding to your ORIGINAL POWER FACTOR until you reach the column that shows your desired CORRECTED POWER FACTOR.
4. Read the number that you find at the intersection of the row and column. Multiply your kW Demand by this number to calculate that total amount of capacitor kVAR you need to install to your electric service.

5. If your plant operates with a 3-phase demand of 410 kW and operates at 76% power factor, but you want to correct to 95%:

- a) Find 95% in the CORRECTED POWER FACTOR row at the top of the page.
- b) Find 76% in the ORIGINAL POWER FACTOR column along the left edge of the page. Read from left to right along this row until you reach the 95% column.
- c) Read the number at the intersection of the row and column (0.526):

$410 \text{ kW} \times .0526 = 216 \text{ kVAR}$ needed to correct your system to 95% power factor.

- d) $216 / 3 = 72 \text{ kVAR}$ per phase.

DRAFT

EXHIBIT 15

CUSTOMER PLANNED ELECTRIC OUTAGE REQUEST FORM

CUSTOMER INFORMATION

COMPANY NAME: _____

LOCATION ADDRESS: _____

OUTAGE DATE: _____

OUTAGE START TIME: _____

LIST OF OPU TRANSFORMER NUMBERS REQUESTED TO BE DE-ENERGIZED:

ESTIMATED OUTAGE LENGTH: _____

OUTAGE REQUESTED FOR: _____

CONTACT INFORMATION

PRIMARY CONTACT: _____

POSITION: _____

TELEPHONE: _____

SECONDARY CONTACT: _____

POSITION: _____

TELEPHONE: _____

SUBMITTED BY:

SIGNATURE: _____

DATE: _____

PHONE NUMBERS

General Information **507-451-2480**
Repairs or After Business Hours **507-451-1616**
OPU Fax **507-451-4940**
OPU Web Page www.owatonnautilities.com
Underground Location Assistance
One-Call **1-800-252-1166**

Owatonna Public Utilities
208 S. Walnut Avenue
P.O. Box 800
Owatonna, Minnesota 55060-2940